



**23rd Summer
School on
PARALLEL
COMPUTING**

Introduction to Numerical Libraries

Massimiliano Guarrasi - [m.guarrasi@cineca.it](mailto:m.guarrasi@ Cineca.it)
SuperComputing Applications and Innovation Department



- You can find this presentation on:
https://hpc-forge.cineca.it/files/ScuolaCalcoloParallelo_WebDAV/public/anno-2014/23_summer_school/
- An extended version can be found on:
https://hpc-forge.cineca.it/files/CoursesDev/public/2014/HPC_Numerical_Libraries/Bologna/
- Guided exercises
<http://www.hpc.cineca.it/content/numerical-libraries>
- Files:
https://hpc-forge.cineca.it/files/CoursesDev/public/2014/HPC_Numerical_Libraries/Bologna/



1. Parallel FFT libraries:

- FFTW
- 2Decomp&FFT
- P3DFFT

2. Parallel Dense Linear Algebra libraries:

- BLACS
- ScaLAPAC

3. Parallel Sparse Linear Algebra libraries:

- PETSc



**23rd Summer
School on
PARALLEL
COMPUTING**

Part 1:

Introduction to Numerical Fourier Transforms





$$H(f) = \int_{-\infty}^{\infty} h(t) e^{2\pi i f t} dt$$

$$h(t) = \int_{-\infty}^{\infty} H(f) e^{-2\pi i f t} df$$

Frequency Domain

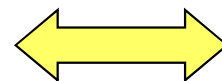

Time Domain

Real Space

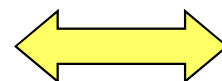

Reciprocal Space



In many application contexts the Fourier transform is approximated with a Discrete Fourier Transform (DFT):

$$H(f_n) = \int_{-\infty}^{\infty} h(t) e^{2\pi i f_n t} dt \approx \sum_{k=0}^{N-1} h_k e^{2\pi i f_n t_k} \Delta = \Delta \sum_{k=0}^{N-1} h_k e^{2\pi i f_n t_k}$$

$$\begin{cases} t_k = \Delta k / N \\ f_n = n / \Delta \end{cases}$$

$$H(f_n) = \Delta \sum_{k=0}^{N-1} h_k e^{2\pi i k n / N}$$

The last expression is periodic, with period N . It defines a relationship between 2 sets of numbers, \mathbf{H}_n & \mathbf{h}_k ($\mathbf{H}(\mathbf{f}_n) = \Delta \mathbf{H}_n$)



$$H_n = \sum_{k=0}^{N-1} h_k e^{2\pi i kn / N}$$

$$h_k = \frac{1}{N} \sum_{n=0}^{N-1} H_n e^{-2\pi i kn / N}$$

frequencies from **0** to **fc** (maximum frequency) are mapped in the values with index from **0** to **N/2-1**, while negative ones are up to **-fc** mapped with index values of **N / 2** to **N**

Scale like N*N



The DFT can be calculated very efficiently using the algorithm known as the FFT, which uses symmetry properties of the DFT s

$$\begin{aligned} F_k &= \sum_{j=0}^{N-1} e^{2\pi ijk/N} f_j \\ &= \sum_{j=0}^{N/2-1} e^{2\pi ik(2j)/N} f_{2j} + \sum_{j=0}^{N/2-1} e^{2\pi ik(2j+1)/N} f_{2j+1} \\ &= \sum_{j=0}^{N/2-1} e^{2\pi ikj/(N/2)} f_{2j} + W^k \sum_{j=0}^{N/2-1} e^{2\pi ikj/(N/2)} f_{2j+1} \\ &= F_k^e + W^k F_k^o \end{aligned}$$



$\exp(2\pi i/N)$

$$F_k = F_k^e + W^k F_k^o$$

DFT of even terms

DFT of odd terms



Now Iterate:

$$F^e = F^{ee} + W^{k/2} F^{eo}$$

$$F^o = F^{oe} + W^{k/2} F^{oo}$$

You obtain a series for each value of f_n

$$F^{oeoeoeoeo..oe} = f_n$$

Scale like $N \cdot \log N$ (binary tree)



Parallel Domain Decomposition

How to compute a FFT on a distributed memory system



- On a 1D array:
 - Algorithm limits:
 - All the tasks must know the whole initial array
 - No advantages in using distributed memory systems
 - Solutions:
 - Using OpenMP it is possible to increase the performance on shared memory systems
- On a Multi-Dimensional array:
 - It is possible to use distributed memory systems



$$\begin{aligned} H(n_1, n_2) &= \text{FFT-on-index-1} (\text{FFT-on-index-2} [h(k_1, k_2)]) \\ &= \text{FFT-on-index-2} (\text{FFT-on-index-1} [h(k_1, k_2)]) \end{aligned}$$

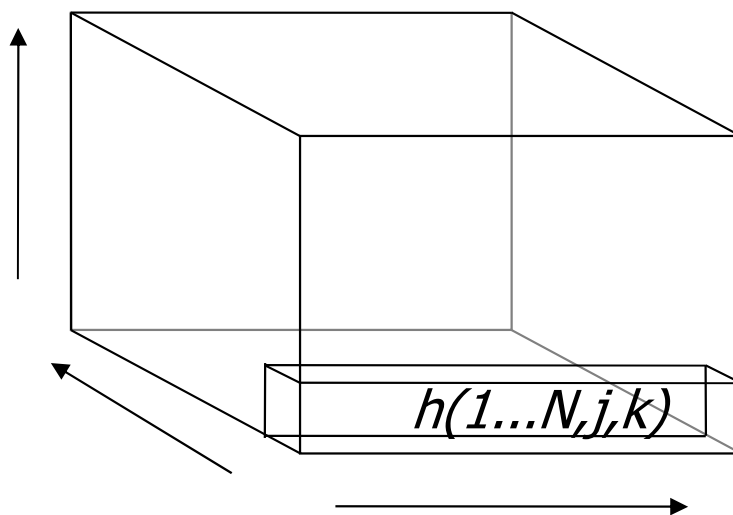

1) For each value of \mathbf{j} and \mathbf{k}
Apply FFT to $h(1...N, j, k)$

2) For each value of \mathbf{i} and \mathbf{k}
Apply FFT to $h(i, 1...N, k)$

3) For each value of \mathbf{i} and \mathbf{j}
Apply FFT to $h(i, j, 1...N)$

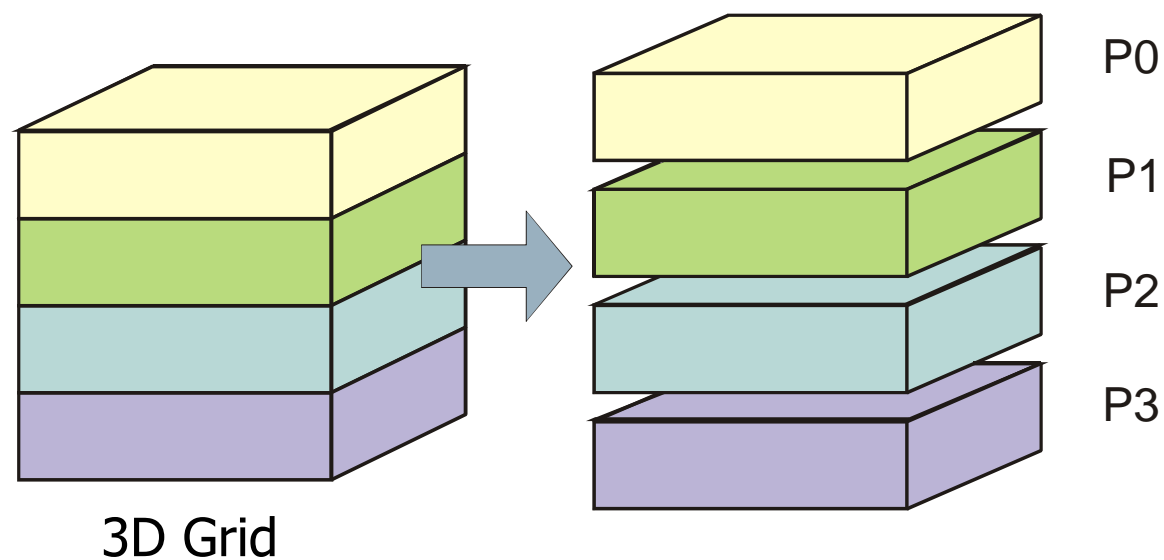

Distribute data along one coordinate (e.g. Z)

This is known as "Slab Decomposition" or 1D Decomposition

Transform along x and y

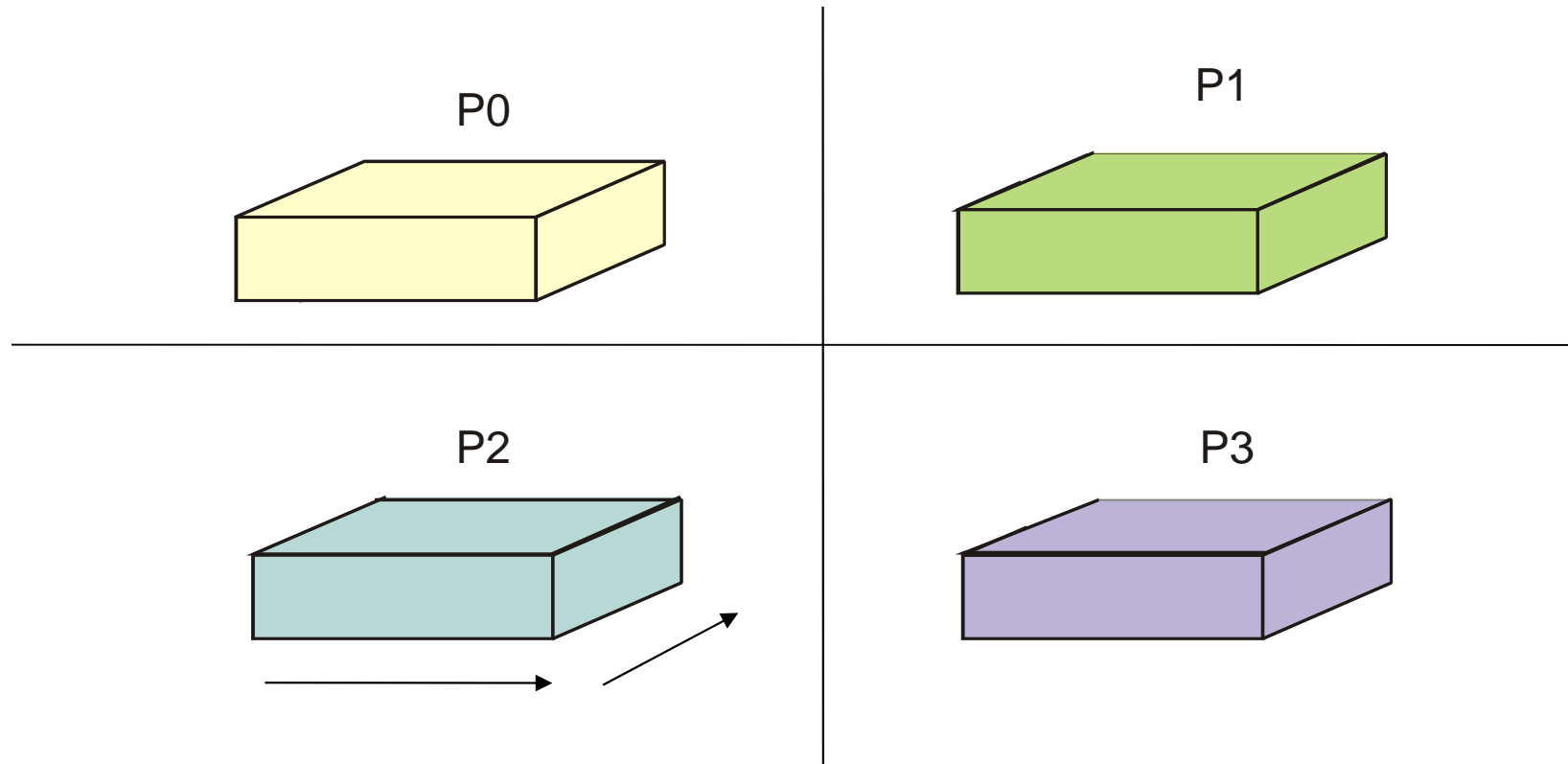

each processor transform its own sub-grid along the x and y independently of the other

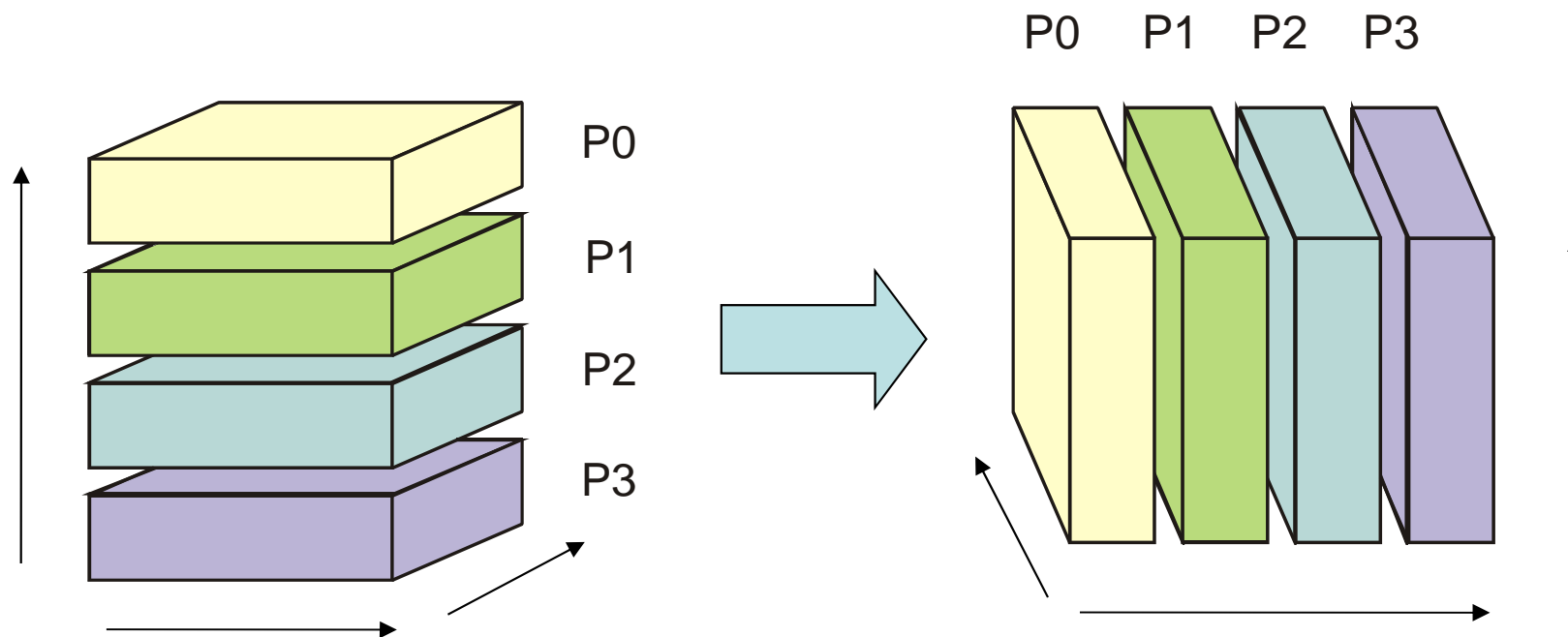

The data are now distributed along x

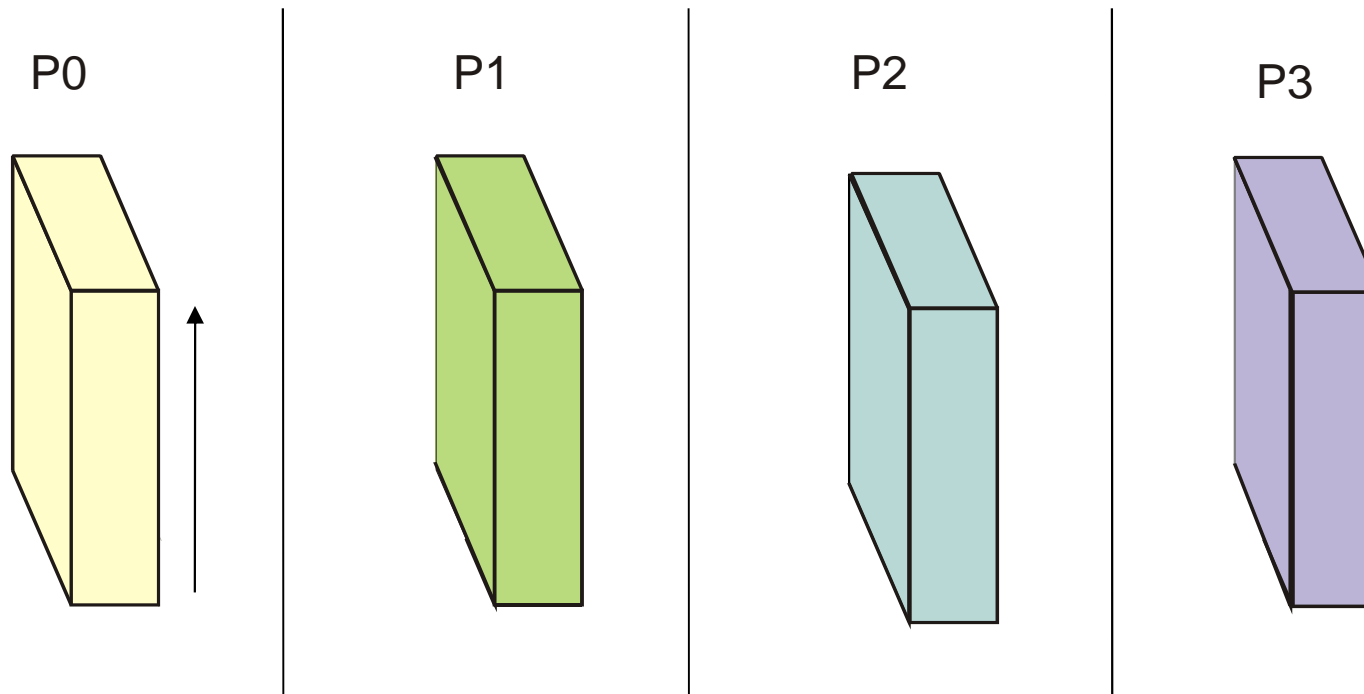

each processor transform its own sub-grid
along the z dimension independently of the other

Data are re-distributed, back from x to z

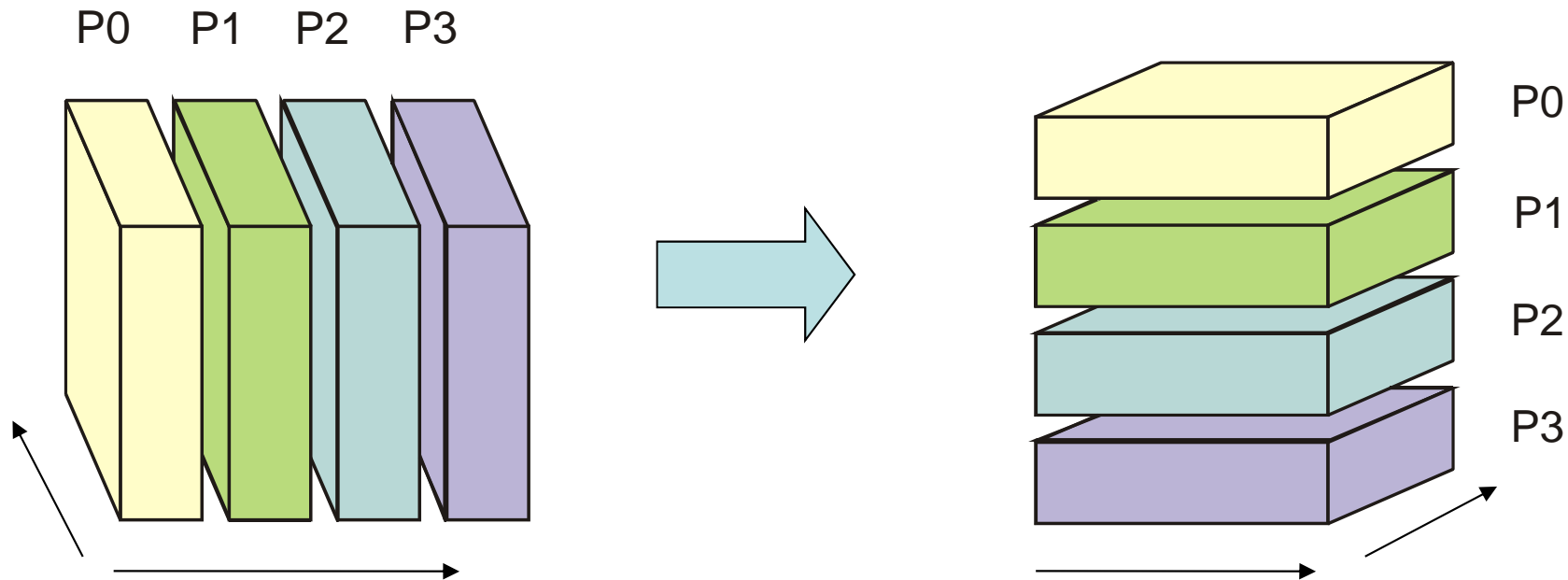

The 3D array now has the original layout, but each element
Has been substituted with its FFT.



- ▶ Pro:
 - ▶ Simply to implement
 - ▶ Moderate communications
- ▶ Con:
 - ▶ Parallelization only along one direction
 - ▶ Maximum number of MPI tasks bounded by the size of the larger array index
- ▶ Possible Solutions:
 - ▶ 2D (Pencil) Decomposition

2D Domain Decomposition

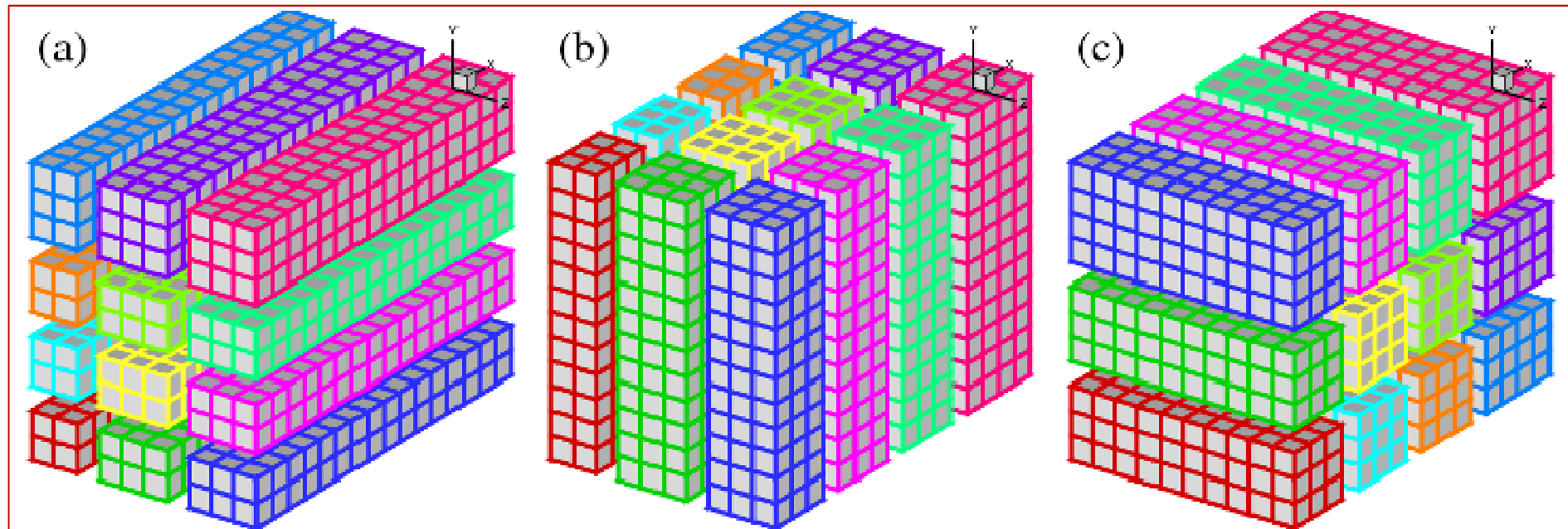



- ▶ Slab (1D) decomposition:
 - ▶ Faster on a limited number of cores
 - ▶ Parallelization is limited by the length of the largest axis of the 3D data array used
- ▶ Pencil (2D) decomposition:
 - ▶ Faster on massively parallel supercomputers
 - ▶ Slower using large size arrays on a moderate number of cores (more MPI communications)



FFT Numerical Libraries

The simplest way to compute a FFT on a modern HPC system



[Download](#) [Mailing List](#) [Benchmark](#) [Features](#) [Documentation](#) [FAQ](#) [Links](#) [Feedback](#)

Introduction

FFTW is a C subroutine library for computing the Discrete Fourier Transform (DFT) in one or more dimensions, of both real and complex data, and of arbitrary input size. We believe that FFTW, which is free software, should become the FFT library of choice for most applications. Our benchmarks, performed on a variety of platforms, show that FFTW's performance is typically superior to that of other publicly available FFT software. Moreover, FFTW's performance is *portable*: the program will perform well on most architectures without modification.

It is difficult to summarize in a few words all the complexities that arise when testing many programs, and there is no "best" or "fastest" program. However, FFTW appears to be the fastest program most of the time for in-order transforms, especially in the multi-dimensional and real-complex cases (Kasparov is the best chess player in the world even though he loses some games). Hence the name, "FFTW," which stands for the somewhat whimsical title of "Fastest Fourier Transform in the West." Please visit the benchFFT home page for a more extensive survey of the results.

The FFTW package was developed at MIT by Matteo Frigo and Steven G. Johnson.



- Written in C
- Fortran wrapper is also provided
- FFTW adapt itself to your machines, your cache, the size of your memory, the number of register, etc...
- FFTW doesn't use a fixed algorithm to make DFT
 - FFTW chose the best algorithm for your machines
- Computation is split in 2 phases:
 - PLAN creation
 - Execution
- FFTW support transforms of data with arbitrary length, rank, multiplicity, and memory layout, and more....



- Many different versions:

- FFTW 2:

- Released in 2003
 - Well tested and used in many codes
 - Includes serial and parallel transforms for both shared and distributed memory system

- FFTW 3:

- Released in February 2012
 - Includes serial and parallel transforms for both shared and distributed memory system
 - Hybrid implementation MPI-OpenMP
 - Last version is FFTW 3.3.3



FFTW

Some Useful Instructions

How can I compile a code that uses FFTW on PLX?

- Module Loading:

```
module load autoload fftw/3.3.3--openmpi--1.6.3--intel--cs-xe-2013--binary
```

- Including header:

- `-I$FFTW_INC`

- Linking:

```
-L$FFTW_LIB -lfftwf3_mpi -lfftwf3_omp -lfftw3f -lm (single precision)
```

```
-L$FFTW_LIB -lfftw3_mpi -lfftw3_omp -lfftw3 -lm (double precision)
```

MPI

OpenMP

- An example:

```
$ mpif90 -O3 -I$FFTW_INC example.F90 -L$FFTW_LIB .lfftw3_mpi -lfftw3_omp .lfftw3 -lm
```

How can I compile a code that uses FFTW on FERMI?



- Module Loading:

```
module load autoload fftw/3.3.2--bgq-gnu--4.4.6
```

- Including header:

- `-I$FFTW3_INC`

- Linking:

```
-L$FFTW3_LIB -lfftw3f_mpi -lfftw3f_omp -lfftw3f -lm (single precision)
```

```
-L$FFTW3_LIB -lfftw3_mpi -lfftw3_omp -lfftw3 -lm (double precision)
```

MPI

OpenMP

- An example:

```
$ mpif90 -O3 -I$FFTW3_INC example.F90 -L$FFTW3_LIB .lfftw3_mpi -lfftw3_omp .lfftw3 -lm
```

- Function in C became function in FORTRAN if they have a return value, and subroutines otherwise.
- All C types are mapped via the `iso_c_binning` standard.
- FFTW plans are `type(C_PTR)` in FORTRAN.
- The ordering of FORTRAN array dimensions must be reversed when they are passed to the FFTW plan creation



Including FFTW Lib:

- C:
 - Serial:
`#include <fftw.h>`
 - MPI:
`#include <fftw-mpi.h>`
- FORTRAN:
 - Serial:
`include 'fftw3.f03'`
 - MPI:
`include 'fftw3-mpi.f03'`

MPI initialization:

- C:
`void fftw_mpi_init(void)`
- FORTRAN:
`fftw_mpi_init()`



C:

- Fixed size array:
`fftw_complex data[n0][n1][n2]`
- Dynamic array:
`data = fftw_alloc_complex(n0*n1*n2)`
- MPI dynamic arrays:
`fftw_complex *data`
`ptrdiff_t alloc_local, local_n0, local_n0_start`
`alloc_local = fftw_mpi_local_size_3d(n0, n1, n2, MPI_COMM_WORLD, &local_n0, &local_n0_start)`
`data = fftw_alloc_complex(alloc_local)`

FORTRAN:

- Fixed size array (simplest way):
`complex(C_DOUBLE_COMPLEX), dimension(n0,n1,n2) :: data`
- Dynamic array (simplest way):
`complex(C_DOUBLE_COMPLEX), allocatable, dimension(:, :, :) :: data`
`allocate (data(n0, n1, n2))`
- Dynamic array (fastest method):
`complex(C_DOUBLE_COMPLEX), pointer :: data(:, :, :))`
`type(C_PTR) :: cdata`
`cdat = fftw_alloc_complex(n0*n1*n2)`
`call c_f_pointer(cdat, data, [n0,n1,n2])`
- MPI dynamic arrays:
`complex(C_DOUBLE_COMPLEX), pointer :: data(:, :, :)`
`type(C_PTR) :: cdat`
`integer(C_INTPTR_T) :: alloc_local, local_n2, local_n2_offset`
`alloc_local = fftw_mpi_local_size_3d(n2, n1, n0, MPI_COMM_WORLD, local_n2, local_n2_offset)`
`cdat = fftw_alloc_complex(alloc_local)`
`call c_f_pointer(cdat, data, [n0,n1,local_n2])`

Plan Creation (C2C)



1D Complex to complex DFT:

• C:

```
fftw_plan = fftw_plan_dft_1d(int nx, fftw_complex *in, fftw_complex *out, fftw_direction dir, unsigned flags)
```

•FORTRAN:

```
plan = ftw_plan_dft_1d(nz, in, out, dir, flags)
```

FFTW_FORWARD
FFTW_BACKWARD

FFTW_ESTIMATE
FFTW_MEASURE

2D Complex to complex DFT:

• C:

```
fftw_plan = fftw_plan_dft_2d(int nx, int ny, fftw_complex *in, fftw_complex *out, fftw_direction dir, unsigned flags)
```

```
fftw_plan = fftw_mpi_plan_dft_2d(int nx, int ny, fftw_complex *in, fftw_complex *out, MPI_COMM_WORLD, fftw_direction dir, int flags)
```

•FORTRAN:

```
plan = ftw_plan_dft_2d(ny, nx, in, out, dir, flags)
```

```
plan = ftw_mpi_plan_dft_2d(ny, nx, in, out, MPI_COMM_WORLD, dir, flags)
```

3D Complex to complex DFT:

• C:

```
fftw_plan = fftw_plan_dft_3d(int nx, int ny, int nz, fftw_complex *in, fftw_complex *out, fftw_direction dir, unsigned flags)
```

```
fftw_plan = fftw_mpi_plan_dft_3d(int nx, int ny, int nz, fftw_complex *in, fftw_complex *out, MPI_COMM_WORLD, fftw_direction dir, int flags)
```

•FORTRAN:

```
plan = ftw_plan_dft_3d(nz, ny, nx, in, out, dir, flags)
```

```
plan = ftw_mpi_plan_dft_3d(nz, ny, nx, in, out, MPI_COMM_WORLD, dir, flags)
```

Plan Creation (R2C)



1D Real to complex DFT:

- C:

```
fftw_plan = fftw_plan_dft_r2c_1d(int nx, double *in, fftw_complex *out, fftw_direction dir, unsigned flags)
```

- FORTRAN:

```
ftw_plan_dft_r2c_1d(nz, in, out, dir, flags)
```

FFTW_FORWARD
FFTW_BACKWARD

FFTW_ESTIMATE
FFTW_MEASURE

2D Real to complex DFT:

- C:

```
fftw_plan = fftw_plan_dft_r2c_2d(int nx, int ny, double *in, fftw_complex *out, fftw_direction dir, unsigned flags)
```

```
fftw_plan = fftw_mpi_plan_dft_r2c_2d(int nx, int ny, double *in, fftw_complex *out, MPI_COMM_WORLD, fftw_direction dir, int flags)
```

- FORTRAN:

```
ftw_plan_dft_r2c_2d(ny, nx, in, out, dir, flags)
```

```
ftw_mpi_plan_dft_r2c_2d(ny, nx, in, out, MPI_COMM_WORLD, dir, flags)
```

3D Real to complex DFT:

- C:

```
fftw_plan = fftw_plan_dft_r2c_3d(int nx, int ny, int nz, fftw_complex *in, fftw_complex *out, fftw_direction dir, unsigned flags)
```

```
fftw_plan = fftw_mpi_plan_dft_r2c_3d(int nx, int ny, int nz, fftw_complex *in, fftw_complex *out, MPI_COMM_WORLD, fftw_direction dir, int flags)
```

- FORTRAN:

```
ftw_plan_dft_r2c_3d(nz, ny, nx, in, out, dir, flags)
```

```
ftw_mpi_plan_dft_r2c_3d(nz, ny, nx, in, out, MPI_COMM_WORLD, dir, flags)
```

Plan Creation (R2C)



1D Real to complex DFT:

- C:

```
fftw_plan = fftw_plan_dft_r2c_1d(int nx, double *in, fftw_complex *out, fftw_direction dir, unsigned flags)
```

- FORTRAN:

```
ftw_plan_dft_r2c_1d(nz, in, out, dir, flags)
```

FFTW_FORWARD
FFTW_BACKWARD

FFTW_ESTIMATE
FFTW_MEASURE

2D Real to complex DFT:

- C:

```
fftw_plan = fftw_plan_dft_r2c_2d(int nx, int ny, double *in, fftw_complex *out, fftw_direction dir, unsigned flags)
```

```
fftw_plan = fftw_mpi_plan_dft_r2c_2d(int nx, int ny, double *in, fftw_complex *out, MPI_COMM_WORLD, fftw_direction dir, int flags)
```

- FORTRAN:

```
ftw_plan_dft_r2c_2d(ny, nx, in, out, dir, flags)
```

```
ftw_mpi_plan_dft_r2c_2d(ny, nx, in, out, MPI_COMM_WORLD, dir, flags)
```

3D Real to complex DFT:

- C:

```
fftw_plan = fftw_plan_dft_r2c_3d(int nx, int ny, int nz, fftw_complex *in, fftw_complex *out, fftw_direction dir, unsigned flags)
```

```
fftw_plan = fftw_mpi_plan_dft_r2c_3d(int nx, int ny, int nz, fftw_complex *in, fftw_complex *out, MPI_COMM_WORLD, fftw_direction dir, int flags)
```

- FORTRAN:

```
ftw_plan_dft_r2c_3d(nz, ny, nx, in, out, dir, flags)
```

```
ftw_mpi_plan_dft_r2c_3d(nz, ny, nx, in, out, MPI_COMM_WORLD, dir, flags)
```



Complex to complex DFT:

- C:

```
void fftw_execute_dft(fftw_plan plan, fftw_complex *in, fftw_complex *out)
```

```
void fftw_mpi_execute_dft (fftw_plan plan, fftw_complex *in, fftw_complex *out)
```

- FORTRAN:

```
fftw_execute_dft (plan, in, out)
```

```
fftw_mpi_execute_dft (plan, in, out)
```

Real to complex DFT:

- C:

```
void fftw_execute_dft (fftw_plan plan, double *in, fftw_complex *out)
```

```
void fftw_mpi_execute_dft (fftw_plan plan, double *in, fftw_complex *out)
```

- FORTRAN:

```
fftw_execute_dft (plan, in, out)
```

```
Fftw_mpi_execute_dft (plan, in, out)
```



Destroying PLAN:

- C:
`void fftw_destroy_plan(fftw_plan plan)`
- FORTRAN:
`fftw_destroy_plan(plan)`

FFTW MPI cleanup:

- C:
`void fftw_mpi_cleanup ()`
- FORTRAN:
`fftw_mpi_cleanup ()`

Deallocate data:

- C:
`void fftw_free (fftw_complex data)`
- FORTRAN:
`fftw_free (data)`



FFTW

Some Useful Examples



```
program FFTW1D
  use, intrinsic :: iso_c_binding
  implicit none
  include 'fftw3.f03'
  integer(C_INTPTR_T):: L = 1024
  integer(C_INT) :: LL
  type(C_PTR) :: plan1
  complex(C_DOUBLE_COMPLEX), dimension(1024) :: idata, odata
  integer :: i
  character(len=41), parameter :: filename='serial_data.txt'
  LL = int(L,C_INT)
  !! create MPI plan for in-place forward DF
  plan1 = fftw_plan_dft_1d(LL, idata, odata, FFTW_FORWARD, FFTW_ESTIMATE)
  !! initialize data
  do i = 1, L
    if (i .le. (L/2)) then
      idata(i) = (1.,0.)
    else
      idata(i) = (0.,0.)
    endif
  end do
  !! compute transform (as many times as desired)
  call fftw_execute_dft(plan1, idata, odata)
  !! deallocate and destroy plans
  call fftw_destroy_plan(plan1)
end
```



```
# include <stdlib.h>
# include <stdio.h>
# include <math.h>
# include <fftw3.h>

int main ( void )

{
    ptrdiff_t i;
    const ptrdiff_t n = 1024;
    fftw_complex *in;
    fftw_complex *out;
    fftw_plan plan_forward;
    /* Create arrays. */
    in = fftw_malloc ( sizeof ( fftw_complex ) * n );
    out = fftw_malloc ( sizeof ( fftw_complex ) * n );
    /* Initialize data */
    for ( i = 0; i < n; i++ ) {
        if ( i <= (n/2-1) ) {
            in[i][0] = 1.;
            in[i][1] = 0.;
        }
        else {
            in[i][0] = 0.;
            in[i][1] = 0.;
        }
    }
    /* Create plans. */
    plan_forward = fftw_plan_dft_1d ( n, in, out, FFTW_FORWARD, FFTW_ESTIMATE );
    /* Compute transform (as many times as desired) */
    fftw_execute ( plan_forward );
    /* deallocate and destroy plans */
    fftw_destroy_plan ( plan_forward );
    fftw_free ( in );
    fftw_free ( out );
    return 0;
}
```

2D Parallel FFT – C (part1)



```
# include <stdlib.h>
# include <stdio.h>
# include <math.h>
# include <mpi.h>
# include <fftw3-mpi.h>

int main(int argc, char **argv)
{
    const ptrdiff_t L = 1024, M = 1024;
    fftw_plan plan;
    fftw_complex *data ;
    ptrdiff_t alloc_local, local_L, local_L_start, i, j, ii;
    double xx, yy, rr, r2, t0, t1, t2, t3, tplan, texec;
    const double amp = 0.25;
    /* Initialize */
    MPI_Init(&argc, &argv);
    fftw_mpi_init();

    /* get local data size and allocate */
    alloc_local = fftw_mpi_local_size_2d(L, M, MPI_COMM_WORLD, &local_L, &local_L_start);
    data = fftw_alloc_complex(alloc_local);
    /* create plan for in-place forward DFT */
    plan = fftw_mpi_plan_dft_2d(L, M, data, data, MPI_COMM_WORLD, FFTW_FORWARD, FFTW_ESTIMATE);
```



```
/* initialize data to some function my_function(x,y) */  
/* ..... */  
/* compute transforms, in-place, as many times as desired */  
    fftw_execute(plan);  
/* deallocate and destroy plans */  
    fftw_destroy_plan(plan);  
    fftw_mpi_cleanup();  
    fftw_free ( data );  
    MPI_Finalize();  
}
```



```
program FFT_MPI_3D
  use, intrinsic :: iso_c_binding
  implicit none
    include 'mpif.h'
  include 'fftw3-mpi.f03'
  integer(C_INTPTR_T), parameter :: L = 1024
  integer(C_INTPTR_T), parameter :: M = 1024
  type(C_PTR) :: plan, cdata
  complex(C_DOUBLE_COMPLEX), pointer :: fdata(:, :)
  integer(C_INTPTR_T) :: alloc_local, local_M, local_j_offset
  integer(C_INTPTR_T) :: i, j
  complex(C_DOUBLE_COMPLEX) :: fout
  integer :: ierr, myid, nproc
```

! Initialize

```
  call mpi_init(ierr)
  call MPI_COMM_SIZE(MPI_COMM_WORLD, nproc, ierr)
  call MPI_COMM_RANK(MPI_COMM_WORLD, myid, ierr)
  call fftw_mpi_init()
```

! get local data size and allocate (note dimension reversal)

```
  alloc_local = fftw_mpi_local_size_2d(M, L, MPI_COMM_WORLD, local_M, local_j_offset)
  cdata = fftw_alloc_complex(alloc_local)
  call c_f_pointer(cdata, fdata, [L, local_M])
```

! create MPI plan for in-place forward DFT (note dimension reversal)

```
  plan = fftw_mpi_plan_dft_2d(M, L, fdata, fdata, MPI_COMM_WORLD, FFTW_FORWARD, FFTW_MEASURE)
```



! initialize data to some function my_function(i,j)

```
do j = 1, local_M  
  do i = 1, L  
    call initial(i, (j + local_j_offset), L, M, fout)  
    fdata(i, j) = fout  
  end do  
end do
```

! compute transform (as many times as desired)

```
call fftw_mpi_execute_dft(plan, fdata, fdata)!
```

! deallocate and destroy plans

```
call fftw_destroy_plan(plan)  
call fftw_mpi_cleanup()  
call fftw_free(cdata)  
call mpi_finalize(ierr)
```

```
end
```



2DECOMP FFT &

The most important FFT Fortran Library that use 2D (Pencil) Domain Decomposition



- General-purpose 2D pencil decomposition module to support building large-scale parallel applications on distributed memory systems.
- Highly scalable and efficient distributed Fast Fourier Transform module, supporting three dimensional FFTs (both complex-to-complex and real-to-complex/complex-to-real).
- Halo-cell support allowing explicit message passing between neighbouring blocks.
- Parallel I/O module to support the handling of large data sets.
- Shared-memory optimisation on the communication code for multi-code systems.
- Written in Fortran
- Best performance using Fortran 2003 standard
- No C wrapper is already provided
- Structure: Plan Creation – Execution – Plan Destruction
- Uses FFTW lib (or ESSL) to compute 1D transforms
- More efficient on massively parallel supercomputers.
- Well tested
- Additional features



Parallel Three-Dimensional Fast Fourier Transforms (P3DFFT)



- General-purpose 2D pencil decomposition module to support building large-scale parallel applications on distributed memory systems.
- Highly scalable and efficient distributed Fast Fourier Transform module, supporting three dimensional FFTs (both complex-to-complex and real-to-complex/complex-to-real).
- Sine/cosine/Chebyshev/empty transform
- Shared-memory optimisation on the communication code for multi-code systems.
- Written in Fortran 90
- C wrapper is already provided
- Structure: Plan Creation – Execution – Plan Destruction
- Uses FFTW lib (or ESSL) to compute 1D transforms
- More efficient on massively parallel supercomputers.
- Well tested but not stable as 2Decomp&FFT
- Additional features



- ▶ Auto-tuning of the FFTW Library for Massively Parallel Supercomputers.
 - ▶ M. Guarrasi, G. Erbacci, A. Emerson;
 - ▶ 2012, PRACE white paper;
 - ▶ Available at [this link](#);
- ▶ Scalability Improvements for DFT Codes due to the Implementation of the 2D Domain Decomposition Algorithm.
 - ▶ M. Guarrasi, S. Frigio, A. Emerson, G. Erbacci
 - ▶ 2013, PRACE white paper;
 - ▶ Available at [this link](#)
- ▶ Testing and Implementing Some New Algorithms Using the FFTW Library on Massively Parallel Supercomputers.
 - ▶ M. Guarrasi, N. Li, S. Frigio, A. Emerson, G. Erbacci;
 - ▶ Accepted for ParCo 2013 conference proceedings.
- ▶ 2DECOMP&FFT – A highly scalable 2D decomposition library and FFT interface.
 - ▶ N. Li, S. Laizet;
 - ▶ 2010, Cray User Group 2010 conference;
 - ▶ Available at [this link](#)
- ▶ P3DFFT: a framework for parallel computations of Fourier transforms in three dimensions.
 - ▶ D. Pekurovsky;
 - ▶ 2012, SIAM Journal on Scientific Computing, Vol. 34, No. 4, pp. C192-C209
- ▶ The Design and Implementation of FFTW3.
 - ▶ M. Frigio, S. G. Johnson;
 - ▶ 2005, Proceedings of the IEEE.

Links:



Summer
School on
PARALLEL
COMPUTING

FFTW Homepage : <http://www.fftw.org/>

Download FFTW-3: <http://www.fftw.org/fftw-3.3.3.tar.gz>

Manual FFTW-3: <http://www.fftw.org/fftw3.pdf>

2Decomp&FFT homepage: <http://www.2decomp.org/>

Download 2Decomp&FFT: http://www.2decomp.org/download/2decomp_fft-1.5.847.tar.gz

Online Manual 2Decomp&FFT: http://www.2decomp.org/decomp_api.html

P3DFFT homepage: <http://code.google.com/p/p3dfft/>

Download P3DFFT: <http://p3dfft.googlecode.com/files/p3dfft-dist.2.6.1.tar>

Manual P3DFFT:

http://p3dfft.googlecode.com/files/P3DFFT_User_Guide_2.6.1.pdf/



Thank You

For any other info,
Send an email to
m.guarrasi@ Cineca.it



**23rd Summer
School on
PARALLEL
COMPUTING**

Part 2:

Introduction to Scalable Linear Algebra





Linear algebra constitutes the core of most technical-scientific applications

Scalar products

$$s = \sum_i a_i \cdot b_i$$

Linear Systems

$$A_{ij} x_j = b_i$$

Eigenvalue Equations

$$A_{ij} x_j = \alpha x_i$$



Basic Linear Algebra algorithms are well known and largely available. See for instance:

<http://www.nr.com>

Why should I use libraries?

- They are available on many platforms
- ... and they are usually optimized by vendors
- In the case vendor libraries are not installed:

<http://www.netlib.org>



Linear Algebra is Hierarchical

Linear systems, Eigenvalue equations

3 $M \times M$ products

2 $M \times V$ products

1 $V \times V$ products



- BLAS
 - LAPACK
 - PBLAS
 - ScaLAPACK
 - ARPACK
 - P_ARPACK
 - PETSc
- Serial Linear Algebra Packages
- essl (IBM AIX)
 - mkl (Intel)
 - acml (AMD)
 - plasma (ICL – Univ. Tennessee)
 - magma (ICL – Univ. Tennessee) → hybrid
- threaded
- Parallel (distributed) Linear Algebra Packages
(for dense matrices)
- dplasma (ICL – Univ. Tennessee)
- Eigenvalues Problems (for sparse matrices)
- Sparse (non-)Linear Systems



- ARPACK is a collection of Fortran77 subroutines designed to solve large scale eigenvalue problems.
- ARPACK is dependent upon a number of subroutines from LAPACK and the BLAS.
- Main feature: reverse communication interface.
- A parallel version of the ARPACK library is available. The message passing layers currently supported are BLACS and MPI .

(Parallel) Basic Linear Algebra Subprograms (BLAS and PBLAS)



Summer
School on
PARALLEL
COMPUTING

- **Level 1 : Vector - Vector operations**
- **Level 2 : Vector - Matrix operations**
- **Level 3 : Matrix - Matrix operations**

(Scalable) Linear Algebra PACKage (LAPACK and ScaLAPACK)



Summer
School on
PARALLEL
COMPUTING

- **Matrix Decomposition**
- **Linear Equation Systems**
- **Eigenvalue Equations**
- **Linear Least Square Equations**
- **for dense, banded, triangular, real and complex matrices**



Routines name scheme: **XYZZZ**

X data type → S = REAL
D = DOUBLE PRECISION
C = COMPLEX
Z = DOUBLE COMPLEX

YY matrix type (GE = general, SY = symmetric, HE = hermitian)

ZZZ algorithm used to perform computation

Some auxiliary functions don't make use of this naming scheme!



A block representation of a matrix operation constitutes the basic parallelization strategy for dense matrices.

For instance, a matrix-matrix product can be split in a sequence of smaller operations of the same type acting on subblocks of the original matrix

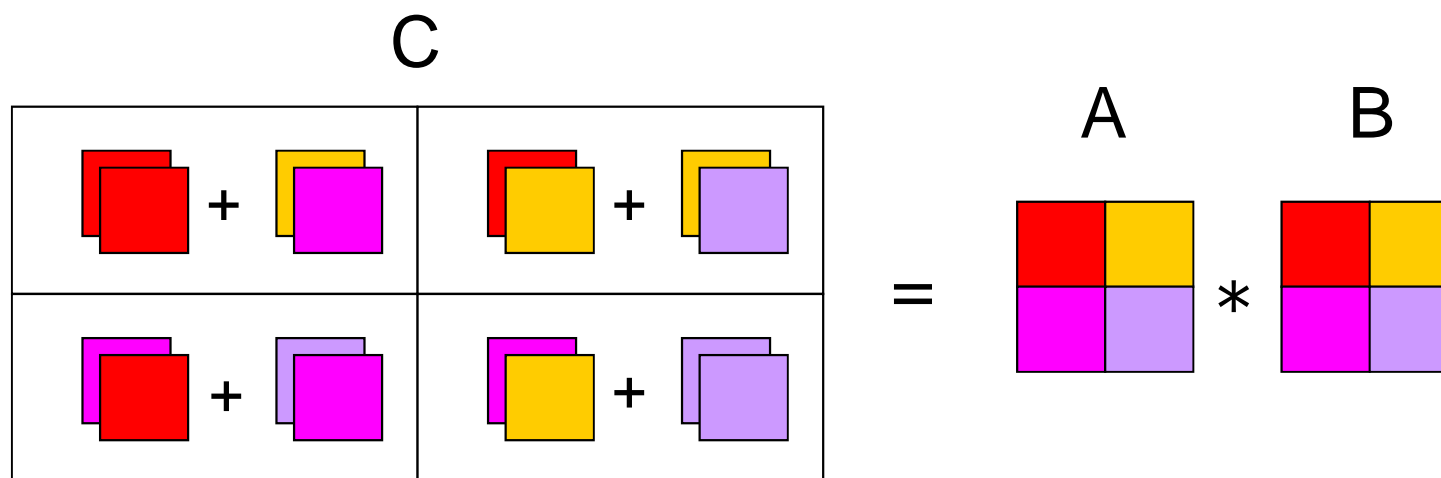

$$c_{ij} = \sum_{k=1}^N a_{ik} \cdot b_{kj}$$

Example: Partitioning into 2x2 Blocks



a11	a12	a13	a14	a15	a16	a17	a18	a19
a21	a22	a23	a24	a25	a26	a27	a28	a29
a31	a32	a33	a34	a35	a36	a37	a38	a39
a41	a42	a43	a44	a45	a46	a47	a48	a49
a51	a52	a53	a54	a55	a56	a57	a58	a59
a61	a62	a63	a64	a65	a66	a67	a68	a69
a71	a72	a73	a74	a75	a76	a77	a78	a79
a81	a82	a83	a84	a85	a86	a87	a88	a89
a91	a92	a93	a94	a95	a96	a97	a98	a99

B ₁₁	B ₁₂	B ₁₃	B ₁₄	B ₁₅
B ₂₁	B ₂₂	B ₂₃	B ₂₄	B ₂₅
B ₃₁	B ₃₂	B ₃₃	B ₃₄	B ₃₅
B ₄₁	B ₄₂	B ₄₃	B ₄₄	B ₄₅
B ₅₁	B ₅₂	B ₅₃	B ₅₄	B ₅₅

Block Representation

Next Step: distribute blocks among processors



N processes are organized into a logical 2D mesh with p rows and q columns, such that $p \times q = N$

		p		
		0	1	2
q	0	rank = 0	rank = 1	rank = 2
	1	rank = 3	rank = 4	rank = 5

A process is referenced by its coordinates within the grid rather than a single number



B_{11}	B_{12}	B_{13}	B_{14}	B_{15}
B_{21}	B_{22}	B_{23}	B_{24}	B_{25}
B_{31}	B_{32}	B_{33}	B_{34}	B_{35}
B_{41}	B_{42}	B_{43}	B_{44}	B_{45}
B_{51}	B_{52}	B_{53}	B_{54}	B_{55}

p

q

	0	1	2	
0	B_{11} B_{31} B_{51}	B_{14} B_{34} B_{54}	B_{12} B_{32} B_{52}	B_{15} B_{35} B_{55}
1	B_{21} B_{41}	B_{24} B_{44}	B_{22} B_{42}	B_{25} B_{45}

Blocks are distributed on processors in a cyclic manner on each index

Some routine can help us to make the best distribution



	0		1		2
0	B ₁₁	B ₁₄	B ₁₂	B ₁₅	B ₁₃
	B ₃₁	B ₃₄	B ₃₂	B ₃₅	B ₃₃
	B ₅₁	B ₅₄	B ₅₂	B ₅₅	B ₅₃
1	B ₂₁	B ₂₄	B ₂₂	B ₂₅	B ₂₃
	B ₄₁	B ₄₄	B ₄₂	B ₄₅	B ₄₃

The indexes of a single element can be traced back to the processor

	0				1			2	
0	a ₁₁	a ₁₂	a ₁₇	a ₁₈	a ₁₃	a ₁₄	a ₁₉	a ₁₅	a ₁₆
	a ₂₁	a ₂₂	a ₂₇	a ₂₈	a ₂₃	a ₂₄	a ₂₉	a ₂₅	a ₂₆
	a ₅₁	a ₅₂	a ₅₇	a ₅₈	a ₅₃	a ₅₄	a ₅₉	a ₅₅	a ₅₆
	a ₆₁	a ₆₂	a ₆₇	a ₆₈	a ₆₃	a ₆₄	a ₆₉	a ₆₅	a ₆₆
	a ₉₁	a ₉₂	a ₉₇	a ₉₈	a ₉₃	a ₉₄	a ₉₉	a ₉₅	a ₉₆
1	a ₃₁	a ₃₂	a ₃₇	a ₃₈	a ₃₃	a ₃₄	a ₃₉	a ₃₅	a ₃₆
	a ₄₁	a ₄₂	a ₄₇	a ₄₈	a ₄₃	a ₄₄	a ₄₉	a ₄₅	a ₄₆
	a ₇₁	a ₇₂	a ₇₇	a ₇₈	a ₇₃	a ₇₄	a ₇₉	a ₇₅	a ₇₆
	a ₈₁	a ₈₂	a ₈₇	a ₈₈	a ₈₃	a ₈₄	a ₈₉	a ₈₅	a ₈₆

myid=0	myid=1	myid=2	myid=3	myid=4	myid=5
p=0 q=0	p=0 q=1	p=0 q=2	p=1 q=0	p=1 q=1	p=1 q=2



a ₁₁	a ₁₂	a ₁₃	a ₁₄	a ₁₅	a ₁₆	a ₁₇	a ₁₈	a ₁₉
a ₂₁	a ₂₂	a ₂₃	a ₂₄	a ₂₅	a ₂₆	a ₂₇	a ₂₈	a ₂₉
a ₃₁	a ₃₂	a ₃₃	a ₃₄	a ₃₅	a ₃₆	a ₃₇	a ₃₈	a ₃₉
a ₄₁	a ₄₂	a ₄₃	a ₄₄	a ₄₅	a ₄₆	a ₄₇	a ₄₈	a ₄₉
a ₅₁	a ₅₂	a ₅₃	a ₅₄	a ₅₅	a ₅₆	a ₅₇	a ₅₈	a ₅₉
a ₆₁	a ₆₂	a ₆₃	a ₆₄	a ₆₅	a ₆₆	a ₆₇	a ₆₈	a ₆₉
a ₇₁	a ₇₂	a ₇₃	a ₇₄	a ₇₅	a ₇₆	a ₇₇	a ₇₈	a ₇₉
a ₈₁	a ₈₂	a ₈₃	a ₈₄	a ₈₅	a ₈₆	a ₈₇	a ₈₈	a ₈₉
a ₉₁	a ₉₂	a ₉₃	a ₉₄	a ₉₅	a ₉₆	a ₉₇	a ₉₈	a ₉₉

Logical View (Matrix)

a ₁₁	a ₁₂	a ₁₇	a ₁₈	a ₁₃	a ₁₄	a ₁₉	a ₁₅	a ₁₆
a ₂₁	a ₂₂	a ₂₇	a ₂₈	a ₂₃	a ₂₄	a ₂₉	a ₂₅	a ₂₆
a ₅₁	a ₅₂	a ₅₇	a ₅₈	a ₅₃	a ₅₄	a ₅₉	a ₅₅	a ₅₆
a ₆₁	a ₆₂	a ₆₇	a ₆₈	a ₆₃	a ₆₄	a ₆₉	a ₆₅	a ₆₆
a ₉₁	a ₉₂	a ₉₇	a ₉₈	a ₉₃	a ₉₄	a ₉₉	a ₉₅	a ₉₆
a ₃₁	a ₃₂	a ₃₇	a ₃₈	a ₃₃	a ₃₄	a ₃₉	a ₃₅	a ₃₆
a ₄₁	a ₄₂	a ₄₇	a ₄₈	a ₄₃	a ₄₄	a ₄₉	a ₄₅	a ₄₆
a ₇₁	a ₇₂	a ₇₇	a ₇₈	a ₇₃	a ₇₄	a ₇₉	a ₇₅	a ₇₆
a ₈₁	a ₈₂	a ₈₇	a ₈₈	a ₈₃	a ₈₄	a ₈₉	a ₈₅	a ₈₆

Local View (CPUs)

<http://acts.nersc.gov/scalapack/hands-on/datadist.html>

<http://acts.nersc.gov/scalapack/hands-on/addendum.html>



(**B**asic **L**inear **A**lgebra **C**ommunication **S**ubprograms)

The BLACS project is an ongoing investigation whose purpose is to create a linear algebra oriented message passing interface that may be implemented efficiently and uniformly across a large range of distributed memory platforms

ScaLAPACK

BLACS

Communication Library
(MPI)



Processes are distributed on a 2D mesh using row-order or column-order (ORDER='R' or 'C'). Each process is assigned a row/column ID as well as a scalar ID

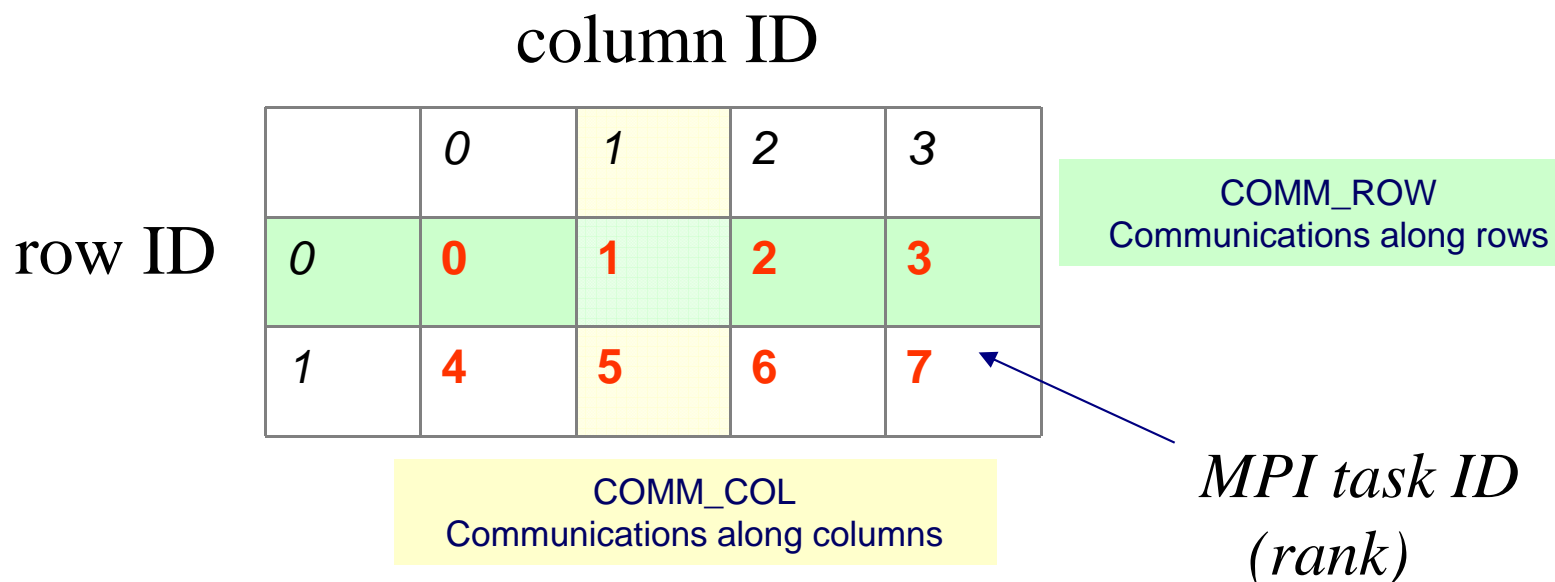

BLACS_GRIDINIT(CONTEXT, ORDER, NPROW, NPCOL)

Initialize a 2D grid of **NPROW** x **NPCOL** processes with an order specified by **ORDER** in a given **CONTEXT**

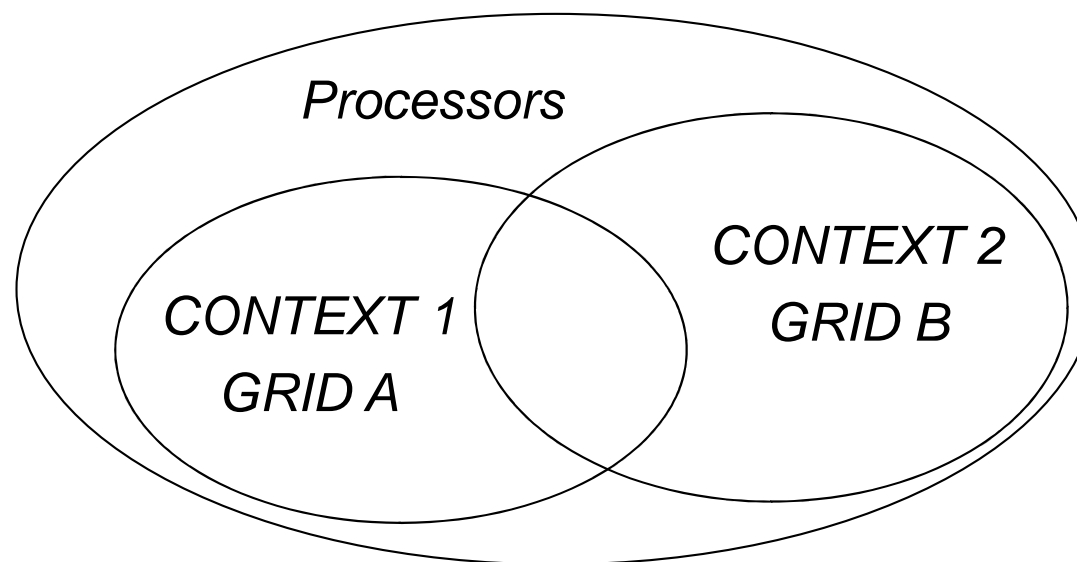

Context



MPI Communicators



BLACS_PINFO(MYPNUM, NPROCS)

Query the system for process ID **MYPNUM** (output) and number of processes **NPROCS** (output).

BLACS_GET(ICONTEXT, WHAT, VAL)

Query to BLACS environment based on **WHAT** (input) and **ICONTTEXT** (input)
If **WHAT=0**, **ICONTTEXT** is ignored and the routine returns in **VAL** (output) a value indicating the default system context

BLACS_GRIDINIT(CONTEXT, ORDER, NPROW, NPCOL)

Initialize a 2D mesh of processes

BLACS_GRIDINFO(CONTEXT, NPROW, NPCOL, MYROW, MYCOL)

Query **CONTEXT** for the dimension of the grid of processes (**NPROW**, **NPCOL**) and for row-ID and col-ID (**MYROW**, **MYCOL**)

BLACS_GRIDEXIT(CONTEXT)

Release the 2D mesh associated with **CONTEXT**

BLACS_EXIT(CONTINUE)

Exit from BLACS environment



Point to Point Communication

DGESD2D(ICONTEX , M , N , A , LDA , RDEST , CDEST)

Send matrix A(M,N) to process (RDEST,CDEST)

DGERV2D(ICONTEX , M , N , A , LDA , RSOUR , CSOUR)

Receive matrix A(M,N) from process (RSOUR,CSOUR)

Broadcast

DGEB2D(ICONTEX , SCOPE , TOP , M , N , A , LDA)

Execute a Broadcast of matrix A(M,N)

DGEBR2D(ICONTEX , SCOPE , TOP , M , N , A , LDA , RSRC , CSRC)

Receive matrix A(M,N) sent from process (RSRC,CSRC) with a broadcast operation

Global reduction

DGSUM2D(ICONTXT , SCOPE , TOP , M , N , A , LDA , RDST , CDST)

Execute a parallel element-wise sum of matrix A(M,N) and store the result in process (RDST,CDST) buffer

<http://www.netlib.org/blacs/BLACS/QRef.html>

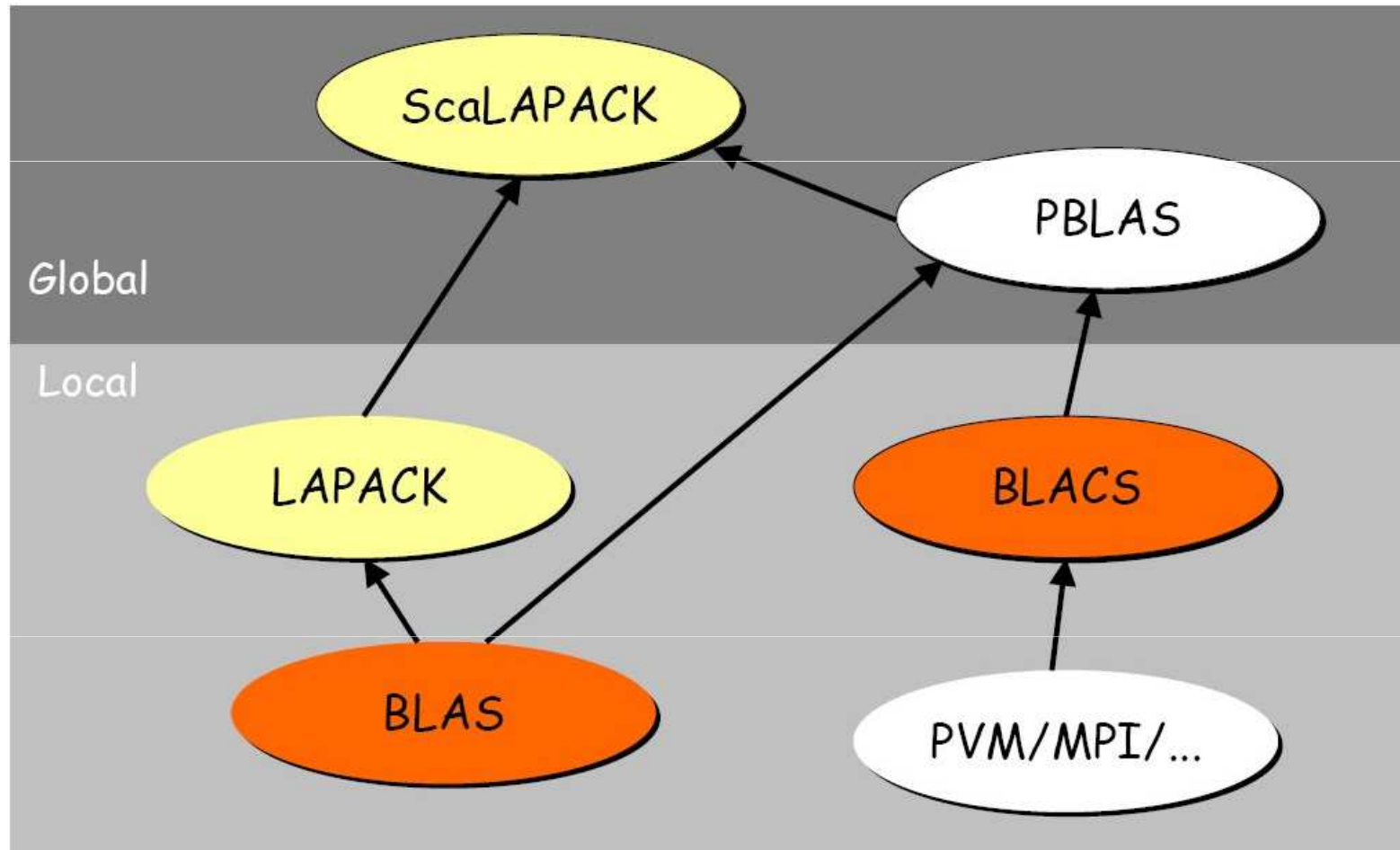



1. *Initialize BLACS*
2. *Initialize BLACS grids*
3. *Distribute matrix among grid processes (cyclic block distribution)*
4. *Calls to ScaLAPACK/PBLAS routines*
5. *Harvest results*
6. *Release BLACS grids*
7. *Close BLACS environment*



```
!      Initialize the BLACS

CALL BLACS_PINFO( IAM, NPROCS )

!      Set the dimension of the 2D processors grid

CALL GRIDSETUP( NPROCS, NPROW, NPCOL ) ! User defined

write (*,100) IAM, NPROCS, NPROW, NPCOL
100  format(' MYPE ',I3,', NPE ',I3,', NPE ROW ',I3,', NPE COL
',I3)

!      Initialize a single BLACS context

CALL BLACS_GET( -1, 0, CONTEXT )
CALL BLACS_GRIDINIT( CONTEXT, 'R', NPROW, NPCOL )
CALL BLACS_GRIDINFO( CONTEXT, NPROW, NPCOL, MYROW, MYCOL )
.....
.....
CALL BLACS_GRIDEXIT( CONTEXT )
CALL BLACS_EXIT( 0 )
```



The Descriptor is an integer array that stores the information required to establish the mapping between each global array entry and its corresponding process and memory location.

Each matrix **MUST** be associated with a Descriptor. Anyhow it's responsibility of the programmer to distribute the matrix coherently with the Descriptor.

<code>DESCA(1) = 1</code>	<code>DESCA(2) = ICTXT</code>
<code>DESCA(3) = M</code>	<code>DESCA(4) = N</code>
<code>DESCA(5) = MB</code>	<code>DESCA(6) = NB</code>
<code>DESCA(7) = RSRC</code>	<code>DESCA(8) = CSRC</code>
<code>DESCA(9) = LDA</code>	



DESCINIT(DESCA, M, N, MB, NB, RSRC, CSRC, ICTXT, LDA, INFO)

DESCA(9) (global output) matrix A ScaLAPACK Descriptor

M, N (global input) global dimensions of matrix A

MB, NB (global input) blocking factors used to distribute matrix A

RSRC, CSRC (global input) process coordinates over which the first element of A is distributed

ICTXT (global input) BLACS context handle, indicating the global context of the operation on matrix

LDA (local input) leading dimension of the local array (depends on process!)



<http://www.netlib.org/scalapack/tools>

Computation of the local matrix size for a $M \times N$ matrix distributed over processes in blocks of dimension $MB \times NB$

```
Mloc = NUMROC( M, MB, ROWID, 0, NPROW )  
Nloc = NUMROC( N, NB, COLID, 0, NPCOL )  
allocate( Aloc( Mloc, Nloc ) )
```

Computation of local and global indexes

```
iloc = INDYG2L( i, MB, ROWID, 0, NPROW )  
jloc = INDYG2L( j, NB, COLID, 0, NPCOL )  
  
i = INDXL2G( iloc, MB, ROWID, 0, NPROW )  
j = INDXL2G( jloc, NB, COLID, 0, NPCOL )
```



Compute the process to which a certain global element (i, j) belongs

```
iprow = INDXG2P( i, MB, ROWID, 0, NPROW )  
jpcol = INDXG2P( j, NB, COLID, 0, NPCOL )
```

Define/read a local element, knowing global indexes

```
CALL PDELSET( A, i, j, DESCA, aval )
```

local array

input value

```
CALL PDELGET( SCOPE, TOP, aval, A, i, j, DESCA )
```

output value

character*1 topology of the broadcast 'D' or 'I'

character*1 scope broadcast 'R', 'C' or 'A'



Routines name scheme:

PXYZZZ



Parallel

X data type

→

S = REAL

D = DOUBLE PRECISION

C = COMPLEX

Z = DOUBLE COMPLEX

YY matrix type (GE = general, SY = symmetric, HE = hermitian)

ZZZ algorithm used to perform computation

Some auxiliary functions don't make use of this naming scheme!



- It's responsibility of the programmer to correctly distribute a global matrix before calling ScaLAPACK routines
- ScaLAPACK routines are written using a message passing paradigm, therefore each subroutine access directly ONLY local data
- Each process of a given CONTEXT must call the same ScaLAPACK routine...
- ... providing in input its local portion of the global matrix
- Operations on matrices distributed on processes belonging to different contexts are not allowed



matrix multiplication: $C = A * B$ (level 3)

```
PDGEMM('N', 'N', M, N, L, 1.0d0, A, 1, 1, DESC_A, B, 1, 1, DESC_B, 0.0d0, C, 1, 1, DESC_C)
```

matrix transposition: $C = A'$ (level 3)

```
PDTRAN( M, N, 1.0d0, A, 1, 1, DESC_A, 0.0d0, C, 1, 1, DESC_C )
```

matrix times vector: $Y = A * X$ (level 2)

```
PDGEMV('N', M, N, 1.0d0, A, 1, 1, DESC_A, X, 1, JX, DESC_X, 1, 0.0d0, Y, 1, JY, DESC_Y, 1)
```

$X(1:N, JX:JX)$

$Y(1:M, JY:JY)$

row / column swap: $X \Leftrightarrow Y$ (level 1)

```
PDSWAP( N, X, IX, JX, DESC_X, INCX, Y, IY, JY, DESC_Y, INCY )
```

$X(IX, JX:JX+N-1)$ if $INCX = M_X$, $X(IX:IX+N-1, JX)$ if $INCX = 1$ and $INCX \neq M_X$,

$Y(IY, JY:JY+N-1)$ if $INCY = M_Y$, $Y(IY:IY+N-1, JY)$ if $INCY = 1$ and $INCY \neq M_Y$.

scalar product: $p = X' \cdot Y$ (level 1)

```
PDDOT( N, p, X, IX, JX, DESC_X, INCX, Y, IY, JY, DESC_Y, INCY )
```

$X(IX, JX:JX+N-1)$ if $INCX = M_X$, $X(IX:IX+N-1, JX)$ if $INCX = 1$ and $INCX \neq M_X$,

$Y(IY, JY:JY+N-1)$ if $INCY = M_Y$, $Y(IY:IY+N-1, JY)$ if $INCY = 1$ and $INCY \neq M_Y$.



Eigenvalues and, optionally, eigenvectors: $A Z = w Z$

```
PDSYEV( 'V', 'U', N, A, 1, 1, DESCA, W, Z, 1, 1, DESCZ, WORK, LWORK, INFO )
```

'U' use upper triangular part of A
'L' use lower triangular part of A

if `lwork = -1`, compute workspace dimension.
Return it in `work(1)`

'V' compute eigenvalues and eigenvectors
'N' compute eigenvalues only

Print matrix

```
PDLAPRNT( M, N, A, 1, 1, DESCA, IR, IC, CMATNM, NOUT, WORK )
```

M	global first dimension of A	IR, IC	coordinates of the printing process
N	global second dimension of A	CMATNM	character*(*) title of the matrix
A	local part of matrix A	NOUT	output fortran units (0 stderr, 6 stdout)
DESCA	descriptor of A	WORK	workspace



<http://www.netlib.org/scalapack/slug/>

**At the end of the “Contents” you can find the
“Quick Reference Guides”
for ScaLAPACK, PBLAS and BLACS routines**



It is quite tricky to write a program using BLACS as a communication library, therefore:



MPI and BLACS must be used consistently!



```
CALL MPI_INIT(IERR)
CALL MPI_COMM_SIZE(MPI_COMM_WORLD,NPROC,IERR)
CALL MPI_COMM_RANK(MPI_COMM_WORLD,MPIME,IERR)
!
comm_world = MPI_COMM_WORLD
!
ndims = 2
dims = 0
CALL MPI_DIMS_CREATE( NPROC, ndims, dims, IERR)

NPROW = dims(1) ! cartesian direction 0
NPCOL = dims(2) ! cartesian direction 1

! Get a default BLACS context
!
CALL BLACS_GET( -1, 0, ICONTEXT )

! Initialize a default BLACS context
CALL BLACS_GRIDINIT(ICONTEXT, 'R', NPROW, NPCOL)
CALL BLACS_GRIDINFO(ICONTEXT, NPROW, NPCOL, ROWID, COLID)

CALL MPI_COMM_SPLIT(comm_world, COLID, ROWID, COMM_COL, IERR)
CALL MPI_COMM_RANK(COMM_COL, coor(1), IERR)
!
CALL MPI_COMM_SPLIT(comm_world, ROWID, COLID, COMM_ROW, IERR)
CALL MPI_COMM_RANK(COMM_ROW, coor(2), IERR)
```

Initialize MPI environment

Compute the dimensions of a
2D mesh compatible with
NPROCS processes

Initialize BLACS process grid
of size nrow x ncol

Create a row and a
column communicator
using BLACS indexes
rowid and colid



```
! Distribute matrix A0 (M x N) from root node to all processes in context ictxt.
!  
call SL_INIT(ICTXT, NPROW, NPCOL)  
call SL_INIT(rootNodeContext, 1, 1) ! create 1 node context  
! for loading matrices  
call BLACS_GRIDINFO( ICTXT, NPROW, NPCOL, MYROW, MYCOL)  
!  
! LOAD MATRIX ON ROOT NODE AND CREATE DESC FOR IT  
!  
if (MYROW == 0 .and. MYCOL == 0) then  
  NRU = NUMROC( M, M, MYROW, 0, NPROW )  
  call DESCINIT( DESCA0, M, N, M, N, 0, 0, rootNodeContext, max(1, NRU), INFO )  
else  
  DESCA0(1:9) = 0  
  DESCA0(2) = -1  
end if  
!  
! CREATE DESC FOR DISTRIBUTED MATRIX  
!  
NRU = NUMROC( M, MB, MYROW, 0, NPROW )  
CALL DESCINIT( DESCA, M, N, MB, NB, 0, 0, ICTXT, max(1, NRU), INFO )  
!  
! DISTRIBUTE DATA  
!  
if (debug) write(*,*) "node r=", MYROW, "c=", MYCOL, "M=", M, "N=", N  
call PDGEMR2D( M, N, A0, 1, 1, DESCA0, A, 1, 1, DESCA, DESCA( 2 ) )
```



- *# load these modules on PLX*
- `module load autoload profile/advanced`
- `module load scalapack/2.0.2-openmpi-1.6.3-gnu-4.5.2`
- `LALIB="-L${SCALAPACK_LIB} -lscalapack \`
- `-L${LAPACK_LIB} -llapack -L${BLAS_LIB} -lblas"`
- *FORTRAN:*
- `mpif90 -o program.x program.f90 ${LALIB}`



- C:

- `// CBLACS PROTOTYPES`
- `extern void Cblacs_pinfo(int* mypnum, int* nprocs);`
- `extern void Cblacs_get(int context, int request, int* value);`
- `extern int Cblacs_gridinit(int* context, char* order, int np_row,`
 - `int np_col);`
- `extern void Cblacs_gridinfo(int context, int* np_row, int* np_col,`
 - `int* my_row, int* my_col);`
- `extern void Cblacs_gridexit(int context);`
- `extern void Cblacs_exit(int error_code);`
- `extern void Cblacs_barrier(int context, char* scope);`



- C:

```
•// BLACS/SCALAPACK PROTOTYPES
•int numroc_( int* n, int* nb, int* iproc, int* isrcproc, int* nprocs );
•void descinit_( int * desca, int * m, int * n, int * mb, int * nb,
•    int * irsrc, int * icsrc, int * context,int * llda, int * info );
•void pdgesv_( int * n, int * nrhs, double * A, int * ia, int * ja,
•    int * desca, int * ipiv, double * b, int * ib, int * jb, int * descb,
•    int * info );
•void pdelset_( double * A, int * i, int * j, int * desca, double * alpha );
•void pdlaprnt_( int * m, int * n, double * A, int * ia, int * ja,
•    int * desca, int * irprnt, int * icprn, char * cmatnm, int * nout,
•    double * work );

•mpicc -o program.x program.c ${LALIB} -lgfortran
```



- *# load these modules on PLX*
- `module load autoloader profile/advanced`
- `module load scalapack/2.0.2-intelmpi--4.1.2--binary`
- `MKL="-I${MKL_INC} -L${MKL_LIB} -lmkl_scalapack_lp64 \`
 - `-lmkl_intel_lp64 -lmkl_core -lmkl_sequential \`
 - `-lmkl_blacs_intelmpi_lp64"`
- `LALIB="-L${SCALAPACK_LIB} -lscalapack"`

- **C:**

- *(remember to include `mkl.h`, `mkl_scalapack.h`, `mkl_blacs.h`)*

- `mpicc -o program.x program.c ${MKL} ${LALIB}`

- **FORTRAN:**

 `mpif90 -o program.x program.f90 ${MKL} ${LALIB}`



Thank You

For any other info,
Send an email to
m.guarrasi@ Cineca.it



**23rd Summer
School on
PARALLEL
COMPUTING**

Part 3:

Introduction to PETSc (Portable, Extensible Toolkit for Scientific Computation)





PETSc – Portable, Extensible Toolkit for Scientific Computation

Is a suite of data structures and routines for the scalable (parallel) solution of scientific applications mainly modelled by partial differential equations.

- **ANL** – Argonne National Laboratory
- Begun September **1991**
- Uses the **MPI** standard for all message-passing communication
- **C, Fortran, and C++**
- Consists of a variety of libraries; each library manipulates a particular family of **objects** and the operations one would like to perform on the objects
- PETSc has been used for modelling in all of these **areas**:
Acoustics, Aerodynamics, Air Pollution, Arterial Flow, Brain Surgery, Cancer Surgery and Treatment, Cardiology, Combustion, Corrosion, Earth Quakes, Economics, Fission, Fusion, Magnetic Films, Material Science, Medical Imaging, Ocean Dynamics, PageRank, Polymer Injection Molding, Seismology, Semiconductors, ...

Relationship between libraries

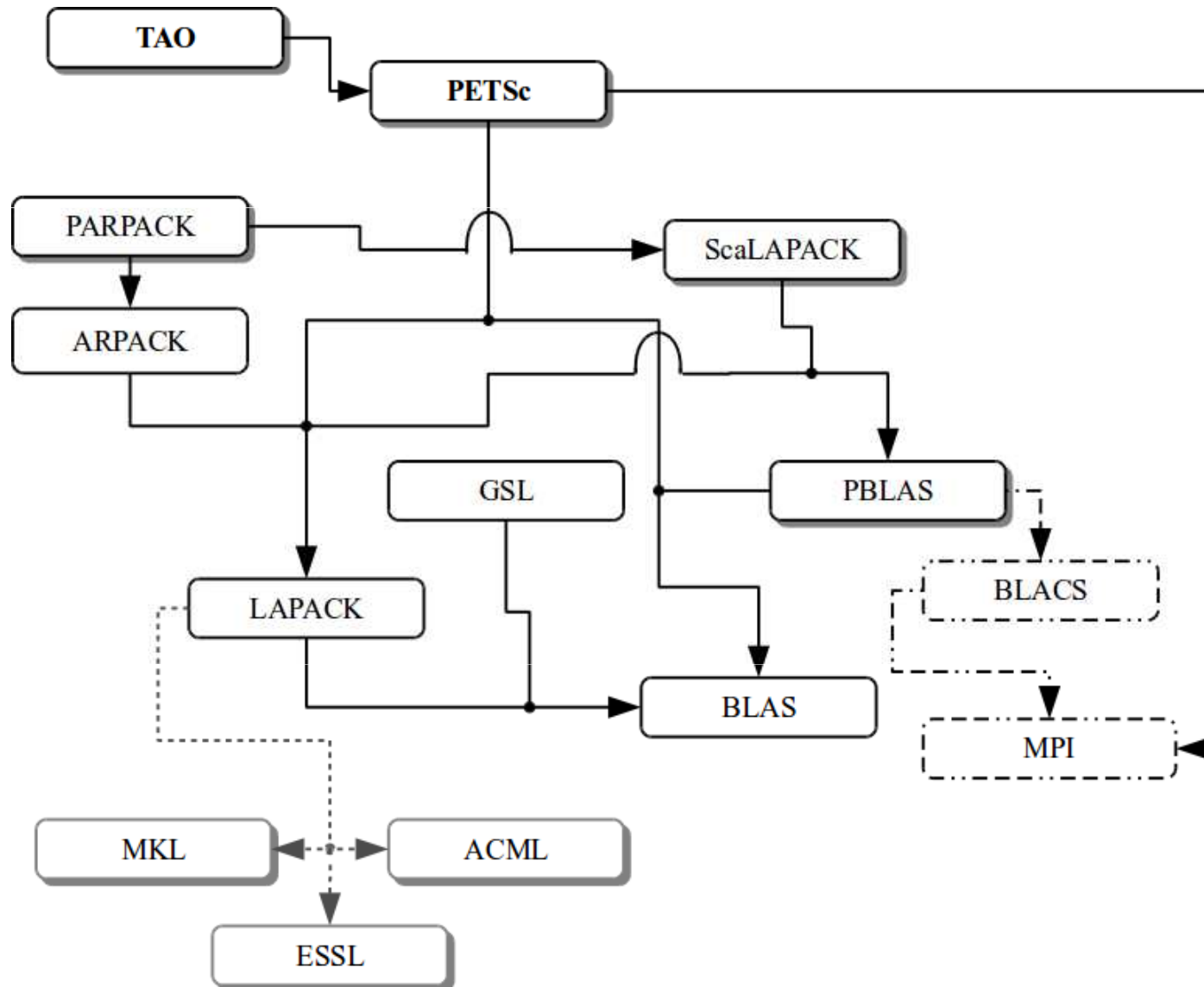



Goals

- Portable
- Performance
- Scalable parallelism

Approach

- Variety of libraries
 - Objects (One interface – One or more implementations)
 - Operations on the objects

Benefit

- Code reuse
- Flexibility
- Hide within objects the details of the communication



Nonlinear Solvers		
Newton-based Methods		Other
Line Search	Trust Region	

Time Steppers			
Euler	Backward Euler	Pseudo-Time Stepping	Other

Krylov Subspace Methods							
GMRES	CG	CGS	Bi-CG-Stab	TFQMR	Richardson	Chebychev	Other

Preconditioners						
Additive Schwarz	Block Jacobi	Jacobi	ILU	ICC	LU (sequential only)	Other

Matrices				
Compressed Sparse Row (AIJ)	Block Compressed Sparse Row (BAIJ)	Block Diagonal (BDiag)	Dense	Other

Vectors

Index Sets			
Indices	Block Indices	Stride	Other

Writing PETSc programs: initialization and finalization



```
PetscInitialize(int *argc, char ***args, const char  
file[], const char help[])
```

- Setup static data and services
- Setup MPI if it is not already

```
PetscFinalize()
```

- Calculates logging summary
- Finalize MPI (if `PetscInitialize()` began MPI)
- Shutdown and release resources



```
#include "petsc.h"

#undef __FUNCT__
#define __FUNCT__ "main"
int main(int argc, char **args)
{
    PetscErrorCode ierr;
    PetscMPIInt    rank;

    PetscInitialize(&argc, &args, (char *)0, PETSC_NULL);

    MPI_Comm_rank(PETSC_COMM_WORLD, &rank);
    ierr = PetscPrintf(PETSC_COMM_SELF, "Hello by procs %d!\n",
                      rank); CHKERRQ(ierr);

    ierr = PetscFinalize();
    return 0;
}
```



```
.  
program main  
  
integer :: ierr, rank  
character(len=6) :: num  
character(len=30) :: hello  
  
#include "finclude/petsc.h"  
  
call PetscInitialize( PETSC_NULL_CHARACTER, ierr )  
  
call MPI_Comm_rank( PETSC_COMM_WORLD, rank, ierr )  
write(num,*) rank  
hello = 'Hello by process '//num  
call PetscPrintf( PETSC_COMM_SELF, hello//achar(10), ierr )  
  
call PetscFinalize(ierr)  
  
end program
```



Vec and Mat



What are PETSc vectors?

- Fundamental objects for storing field solutions, right-hand sides, etc.
- Each process locally owns a subvector of contiguously numbered global indices

Features

- Has a direct interface to the values
- Supports all vector space operations
 - `VecDot()`, `VecNorm()`, `VecScale()`, ...
- Also unusual ops, e.g. `VecSqrt()`, `VecInverse()`
- Automatic communication during assembly
- Customizable communication (scatters)



VecCreate(MPI_Comm comm, Vec *v)

- Vector types: sequential and parallel (MPI based)
- Automatically generates the appropriate vector type (sequential or parallel) over all processes in comm

VecSetSizes(Vec v, int m, int M)

- Sets the local and global sizes, and checks to determine compatibility

VecSetFromOptions(Vec v)

- Configures the vector from the options database

VecDuplicate(Vec old, Vec *new)

- Does not copy the values



```
VecGetSize(Vec v, int *size)
```

```
VecGetLocalSize(Vec v, int *size)
```

```
VecGetOwnershipRange(Vec vec, int *low, int *high)
```

```
VecView(Vec x, PetscViewer v)
```

```
VecCopy(Vec x, Vec y)
```

```
VecSet(Vec x, PetscScalar value)
```

```
VecSetValues(Vec x, int n, int *idx,  
             PetscScalar *v, INSERT_VALUES)
```

```
VecDestroy(Vec *x)
```



Once all of the values have been inserted with `VecSetValues()`, one must call

`VecAssemblyBegin(Vec x)`

`VecAssemblyEnd(Vec x)`

to perform any needed message passing of nonlocal components.

A three step process

- Each process tells PETSc what values to set or add to a vector component. Once *all* values provided,
- begin communication between processes to ensure that values end up where needed (allow other operations, such as some computation, to proceed).
- Complete the communication



```
.  
VecGetSize(x, &N); /* Global size */  
MPI_Comm_rank(PETSC_COMM_WORLD, &rank);  
  
if (rank == 0) {  
    for (i=0; i<N; i++)  
        VecSetValues(x, 1, &i, &i, INSERT_VALUES);  
}  
  
/* These two routines ensure that the data is  
distributed to the other processes */  
VecAssemblyBegin(x);  
VecAssemblyEnd(x);
```



```
VecGetOwnershipRange(x, &low, &high);
```

```
for (i=low; i<high; i++)
```

```
    VecSetValues(x, 1, &i, &i, INSERT_VALUES);
```

```
/* These routines must be called in case some other  
process contributed a value owned by another process  
*/
```

```
VecAssemblyBegin(x);
```

```
VecAssemblyEnd(x);
```



Function Name	Operation
<code>VecAXPY(Vec y, PetscScalar a, Vec x);</code>	$y = y + a * x$
<code>VecAYPX(Vec y, PetscScalar a, Vec x);</code>	$y = x + a * y$
<code>VecWAXPY(Vec w, PetscScalar a, Vec x, Vec y);</code>	$w = a * x + y$
<code>VecAXPBX(Vec y, PetscScalar a, PetscScalar b, Vec x);</code>	$y = a * x + b * y$
<code>VecScale(Vec x, PetscScalar a);</code>	$x = a * x$
<code>VecDot(Vec x, Vec y, PetscScalar *r);</code>	$r = \bar{x}' * y$
<code>VecTDot(Vec x, Vec y, PetscScalar *r);</code>	$r = x' * y$
<code>VecNorm(Vec x, NormType type, PetscReal *r);</code>	$r = x _{type}$
<code>VecSum(Vec x, PetscScalar *r);</code>	$r = \sum x_i$
<code>VecCopy(Vec x, Vec y);</code>	$y = x$
<code>VecSwap(Vec x, Vec y);</code>	$y = x$ while $x = y$
<code>VecPointwiseMult(Vec w, Vec x, Vec y);</code>	$w_i = x_i * y_i$
<code>VecPointwiseDivide(Vec w, Vec x, Vec y);</code>	$w_i = x_i / y_i$
<code>VecMDot(Vec x, int n, Vec y[], PetscScalar *r);</code>	$r[i] = \bar{x}' * y[i]$
<code>VecMTDot(Vec x, int n, Vec y[], PetscScalar *r);</code>	$r[i] = x' * y[i]$
<code>VecMAXPY(Vec y, int n, PetscScalar *a, Vec x[]);</code>	$y = y + \sum_i a_i * x[i]$
<code>VecMax(Vec x, int *idx, PetscReal *r);</code>	$r = \max x_i$
<code>VecMin(Vec x, int *idx, PetscReal *r);</code>	$r = \min x_i$
<code>VecAbs(Vec x);</code>	$x_i = x_i $
<code>VecReciprocal(Vec x);</code>	$x_i = 1/x_i$
<code>VecShift(Vec x, PetscScalar s);</code>	$x_i = s + x_i$
<code>VecSet(Vec x, PetscScalar alpha);</code>	$x_i = \alpha$



It is sometimes more efficient to directly access the storage for the local part of a PETSc `Vec`.

- E.g., for finite difference computations involving elements of the vector

`VecGetArray(Vec, double *[])`

- Access the local storage

`VecRestoreArray(Vec, double *[])`

- You must return the array to PETSc when you finish

Allows PETSc to handle data structure conversions

- For most common uses, these routines are inexpensive and do *not* involve a copy of the vector.



```
.  
Vec vec;  
Double *avec;  
[...]  
VecCreate(PETSC_COMM_WORLD, &vec);  
VecSetSizes(vec, PETSC_DECIDE, n);  
VecSetFromOptions(vec);  
[...]  
VecGetArray(vec, &avec);  
  
/* compute with avec directly, e.g.: */  
PetscPrintf(PETSC_COMM_WORLD,  
            "First element of local array of vec in  
            each process is %f\n", avec[0] );  
  
VecRestoreArray(vec, &avec);
```



```
[...]  
PetscViewer viewer_fd;  
Vec va;  
[...]  
ierr = PetscViewerBinaryOpen(PETSC_COMM_WORLD, "data/va_200.bin",  
                               FILE_MODE_READ, &viewer_fd );CHKERRQ(ierr);  
ierr = VecCreate(PETSC_COMM_WORLD, &va); CHKERRQ(ierr);  
ierr = VecLoad(va, viewer_fd); CHKERRQ(ierr);  
ierr = PetscViewerDestroy(&viewer_fd); CHKERRQ(ierr);  
CHKMEMQ;  
  
VecView(va, PETSC_VIEWER_STDOUT_WORLD);  
  
VecGetSize(va, &size_global); CHKERRQ(ierr);  
VecGetLocalSize(va, &size_local); CHKERRQ(ierr);  
VecGetOwnershipRange(va, &low_idx, &high_idx); CHKERRQ(ierr);  
[...]  
VecDestroy(&va);  
[...]
```



What are PETSc matrices?

- Fundamental objects for storing linear operators
- Each process locally owns a submatrix of contiguous rows

Features

- Supports many data types
 - AIJ, Block AIJ, Symmetric AIJ, Block Diagonal, etc.
- Supports structures for many packages
 - Spooles, MUMPS, SuperLU, UMFPack, DSCPack
- A matrix is defined by its interface, the operations that you can perform with it, not by its data structure



MatCreate(MPI_Comm comm, Mat *A)

- Matrices types: sequential and parallel (MPI based).
- Automatically generates the appropriate matrix type (sequential or parallel) over all processes in comm.

MatSetSizes(Mat A, int m, int n, int M, int N)

- Sets the local and global sizes, and checks to determine compatibility

MatSetFromOptions(Mat A)

- Configures the matrix from the options database.

MatDuplicate(Mat B, MatDuplicateOption op, Mat *A)

- Duplicates a matrix including the non-zero structure.



```
MatView(Mat A, PetscViewer v)
```

```
MatGetOwnershipRange(Mat A, PetscInt *m, PetscInt* n)
```

```
MatGetOwnershipRanges(Mat A, const PetscInt **ranges)
```

- Each process locally owns a submatrix of contiguously numbered global rows.

```
MatGetSize(Mat A, PetscInt *m, PetscInt* n)
```

```
MatSetValues(Mat A, int m, const int idxm[],  
             int n, const int idxn[],  
             const PetscScalar values[],  
             INSERT_VALUES | ADD_VALUES)
```



Once all of the values have been inserted with `MatSetValues()`, one must call

```
MatAssemblyBegin(Mat A, MatAssemblyType type)
```

```
MatAssemblyEnd(Mat A, MatAssemblyType type)
```

to perform any needed message passing of nonlocal components.



```
Mat      A;
int      column[3], i;
double  value[3];
[...]
```

```
MatCreate(PETSC_COMM_WORLD,PETSC_DECIDE,PETSC_DECIDE,n,n,&A);
MatSetFromOptions(A);
```

```
value[0] = -1.0; value[1] = 2.0; value[2] = -1.0;
if (rank == 0) {
    for (i=1; i<n-2; i++) {
        column[0] = i-1; column[1] = i; column[2] = i+1;
        MatSetValues(A,1,&i,3,column,value,INSERT_VALUES);
    }
}
```

```
MatAssemblyBegin(A,MAT_FINAL_ASSEMBLY);
MatAssemblyEnd(A,MAT_FINAL_ASSEMBLY);
```



```
Mat      A;
int      column[3], i, start, end, istart, iend;
double  value[3];
[...]
```

```
MatCreate(PETSC_COMM_WORLD, PETSC_DECIDE, PETSC_DECIDE, n, n, &A);
MatSetFromOptions(A);
MatGetOwnershipRange(A, &istart, &iend);
```

```
value[0] = -1.0; value[1] = 2.0; value[2] = -1.0;
for (i=istart; i<iend; i++) {
    column[0] = i-1; column[1] = i; column[2] = i+1;
    MatSetValues(A, 1, &i, 3, column, value, INSERT_VALUES);
}
```

```
MatAssemblyBegin(A, MAT_FINAL_ASSEMBLY);
MatAssemblyEnd(A, MAT_FINAL_ASSEMBLY);
```



Function Name	Operation
<code>MatAXPY(Mat Y, PetscScalar a, Mat X, MatStructure);</code>	$Y = Y + a * X$
<code>MatMult(Mat A, Vec x, Vec y);</code>	$y = A * x$
<code>MatMultAdd(Mat A, Vec x, Vec y, Vec z);</code>	$z = y + A * x$
<code>MatMultTranspose(Mat A, Vec x, Vec y);</code>	$y = A^T * x$
<code>MatMultTransposeAdd(Mat A, Vec x, Vec y, Vec z);</code>	$z = y + A^T * x$
<code>MatNorm(Mat A, NormType type, double *r);</code>	$r = \ A\ _{type}$
<code>MatDiagonalScale(Mat A, Vec l, Vec r);</code>	$A = \text{diag}(l) * A * \text{diag}(r)$
<code>MatScale(Mat A, PetscScalar a);</code>	$A = a * A$
<code>MatConvert(Mat A, MatType type, Mat *B);</code>	$B = A$
<code>MatCopy(Mat A, Mat B, MatStructure);</code>	$B = A$
<code>MatGetDiagonal(Mat A, Vec x);</code>	$x = \text{diag}(A)$
<code>MatTranspose(Mat A, MatReuse, Mat* B);</code>	$B = A^T$
<code>MatZeroEntries(Mat A);</code>	$A = 0$
<code>MatShift(Mat Y, PetscScalar a);</code>	$Y = Y + a * I$



Preallocation of memory is critical for achieving **good performance** during matrix assembly, as this reduces the number of allocations and copies required.

PETSc sparse matrices are dynamic data structures.
Can **add additional nonzeros freely**.

Dynamically adding many nonzeros

- requires additional memory allocations
- requires copies
- can kill performance

Memory pre-allocation provides the freedom of dynamic data structures plus good performance

Matrix AIJ format



	0	1	2	3	4	5	6	7	8
0	red	red			red				red
1		green			green		green		
2		blue	blue	blue		blue			blue
3	gray			gray			gray		
4		yellow		yellow	yellow				yellow
5		purple	purple				purple	purple	purple

value

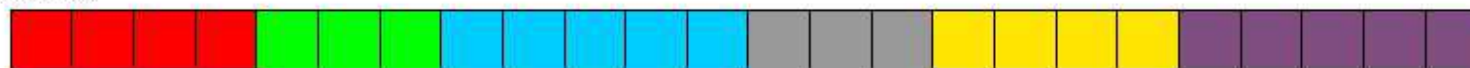

index

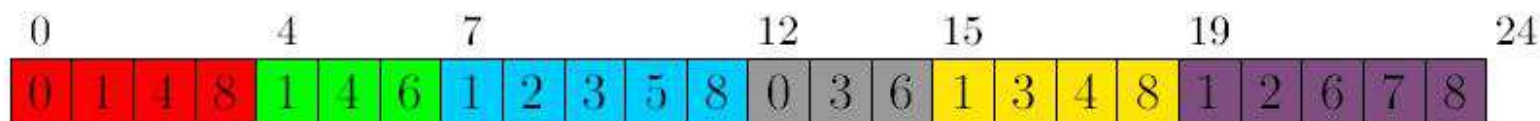

row pointer



Pre-allocation of sequential sparse matrix (1/2)



```
MatCreateSeqAIJ(PETSC_COMM_SELF, int m, int n,  
                int nz, int *nnz, Mat *A)
```

1. If (`nz == 0 && nnz == PETSC_NULL`)

→ PETSc to control all matrix memory allocation

1. Set `nz = <value>`

→ Specify the expected number of nonzeros for each row.

- Fine if the number of nonzeros per row is roughly the same throughout the matrix
- Quick and easy first step for pre-allocation

Pre-allocation of sequential sparse matrix (2/2)



```
MatCreateSeqAIJ(PETSC_COMM_SELF, int m, int n,  
               int nz, int *nnz, Mat *A)
```

3. Set `nnz[0]` = *<nonzeros in row 0>*

...

`nnz[m]` = *<nonzeros in row m>*

→ indicate (nearly) the exact number of elements intended for the various rows

If one **underestimates** the actual number of nonzeros in a given row, then during the assembly process PETSc will **automatically allocate additional needed space**.

This extra memory allocation can **slow** the computation!



Each process locally owns a submatrix of contiguously numbered global rows.

Each submatrix consists of **diagonal** and **off-diagonal** parts.

P0

P1

P2

Pre-allocation of parallel sparse matrix (1/2)



```
MatCreateMPIAIJ(MPI_Comm comm,  
                int m, int n, int M, int N,  
                int d_nz, int *d_nnz,  
                int o_nz, int *o_nnz,  
                Mat *A)
```

1. If ($d_nz == o_nz == 0 \ \&\& \ d_nnz == o_nnz == \text{PETSC_NULL}$)
→ PETSc to control dynamic allocation of matrix memory space
1. Set $d_nz = \langle value \rangle$ and $o_nz = \langle value \rangle$
→ Specify nonzero information for the diagonal (d_nz) and off-diagonal (o_nz) parts of the matrix.

Pre-allocation of parallel sparse matrix (2/2)



```
MatCreateMPIAIJ(MPI Comm comm,  
               int m, int n, int M, int N,  
               int d_nz, int *d_nnz,  
               int o_nz, int *o_nnz,  
               Mat *A)
```

3. Set $d_nnz[0]$ = *<nonzeros in row 0, diagonal part>*
...
 $d_nnz[m]$ = *<nonzeros in row m, diagonal part >*
 $o_nnz[0]$ = *<nonzeros in row 0, off-diagonal part>*
...
 $o_nnz[m]$ = *<nonzeros in row m , off-diagonal part >*
→ Specify nonzero information for the diagonal (d_nnz) and off-diagonal (o_nnz) parts of the matrix.



```
MatGetInfo(Mat mat, MatInfoType flag, MatInfo *info)
```

Or

```
Runtime option: -info -mat_view_info
```

```
typedef struct {  
    PetscLogDouble block_size;  
    PetscLogDouble nz_allocated, nz_used, nz_unneeded;  
    PetscLogDouble memory;  
    PetscLogDouble assemblies;  
    PetscLogDouble mallocs;  
    PetscLogDouble fill_ratio_given, fill_ratio_needed;  
    PetscLogDouble factor_mallocs;  
} MatInfo;
```



[...]

```
MatInfo info;
```

```
Mat A;
```

```
double numMal, nz_a, nz_u;
```

[...]

```
MatGetInfo(A, MAT_LOCAL, &info);
```

```
numMal = info.mallocs;
```

```
nz_a    = info.nz_allocated;
```

```
nz_u    = info.nz_used;
```

[...]



```
[...]  
PetscViewer viewr_fd;  
Mat mC;  
[...]  
ierr = PetscViewerBinaryOpen(PETSC_COMM_WORLD, "data/mC.bin",  
                                FILE_MODE_READ, &viewr_fd ); CHKERRQ(ierr);  
ierr = MatCreate(PETSC_COMM_WORLD, &mC); CHKERRQ(ierr);  
ierr = MatSetType(mC, MATAIJ); CHKERRQ(ierr);  
ierr = MatLoad(mC, viewr_fd); CHKERRQ(ierr);  
ierr = PetscViewerDestroy(&viewr_fd); CHKERRQ(ierr);  
CHKMEMQ;  
  
MatGetSize(mC, &row_global, &col_global); CHKERRQ(ierr);  
MatGetOwnershipRange(mC, &row_local_min, &row_local_max);  
[...]  
MatDestroy( &mC );  
[...]
```



PETSc on

`plx.cineca.it`

Try it!



```
-  
# module load profile/advanced autoload  
    PETSc/3.2-p6--openmpi--1.4.4--intel--co-2011.6.233--binary  
  
# echo $PETSC_DIR  
/cinca/prod/libraries/PETSc/3.2-p6/openmpi--1.4.4--intel--co-2011.6.233--binary  
  
# echo $PETSC_ARCH  
linux-intel  
  
-  
# make  
  
-  
# cp 1_petsc_hello $CINECA_SCRATCH/dir  
# cd $CINECA_SCRATCH/dir  
  
# qsub petscSubmissionScript
```



```
PETSC_DIR = /cineca/prod/libraries/PETSc/3.2-p6/openmpi--1.4.4--intel--co-  
2011.6.233--binary
```

```
PETSC_ARCH = linux-intel
```

```
ALL: 1_petsc_hello
```

```
CFLAGS    = -g -O0
```

```
CPPFLAGS =
```

```
CLEANFILES = 1_petsc_hello
```

```
include ${PETSC_DIR}/conf/variables
```

```
include ${PETSC_DIR}/conf/rules
```

```
1_petsc_hello: 1_petsc_hello.o chkopts
```

```
    -${CLINKER} -o 1_petsc_hello 1_petsc_hello.o ${PETSC_LIB}
```

```
    ${RM} 1_petsc_hello.o
```



1_petsc_hello

- Download the provided source code and data from the course directory.
- Compile the first example.
- Run it!

2_petsc_vec

- Download, compile and run `2_petsc_vec.c`
- Use PETSc vectors:
 - Duplicate a vector
 - Create a vector
 - Set some vector values (remember `VecAssemblyXXX()` calls!)
 - Try some numerical operations

3_petsc_mat

- Download, compile and run `3_petsc_mat.c`
- Use PETSc matrices:
 - Duplicate a matrix
 - Create a matrix
 - Set some matrix values (remember `MatAssemblyXXX()` calls!)
 - Try some numerical operations



Summer
School on
**PARALLEL
COMPUTING**

KSP and SNES



The **object KSP** provides uniform and efficient access to all of the package's **linear system solvers**

KSP is intended for solving nonsingular systems of the form

$$Ax = b.$$

```
KSPCreate(MPI_Comm comm, KSP *ksp)
```

```
KSPSetOperators(KSP ksp, Mat Amat, Mat Pmat,  
               MatStructure flag)
```

```
KSPSolve(KSP ksp, Vec b, Vec x)
```

```
KSPGetIterationNumber(KSP ksp, int *its)
```

```
KSPDestroy(KSP ksp)
```



Method	KSPType	Options Database Name	Default Convergence Monitor†
Richardson	KSPRICHARDSON	richardson	true
Chebyshev	KSPCHEBYCHEV	chebychev	true
Conjugate Gradient [11]	KSPCG	cg	true
BiConjugate Gradient	KSPBICG	bicg	true
Generalized Minimal Residual [15]	KSPGMRES	gmres	precond
BiCGSTAB [18]	KSPBCGS	bcgs	precond
Conjugate Gradient Squared [17]	KSPCGS	cgs	precond
Transpose-Free Quasi-Minimal Residual (1) [7]	KSPTFQMR	tfqmr	precond
Transpose-Free Quasi-Minimal Residual (2)	KSPTCQMR	tcqmr	precond
Conjugate Residual	KSPCR	cr	precond
Least Squares Method	KSPLSQR	lsqr	precond
Shell for no KSP method	KSPPREONLY	preonly	precond

†true - denotes true residual norm, precond - denotes preconditioned residual norm



The SNES class includes methods for solving systems of nonlinear equations of the form

$$F(x) = 0;$$

where $F: \mathbb{R}^n \rightarrow \mathbb{R}^n$.

Newton-like methods provide the core of the package, including both line search and trust region techniques.

```
SNESCreate(MPI Comm comm, SNES *snes)
```

```
SNESsetType(SNES snes, SNESType method)
```

```
SNESsetFunction(SNES snes, Vec f,  
                PetscErrorCode (*FormFunction)  
                (SNES snes, Vec x, Vec f, void *ctx), void *ctx)
```

```
SNESsolve(SNES snes, Vec b, Vec x)
```



Method	SNES Type	Options Name	Default Convergence Test
Line search	SNESLS	ls	SNESConverged_LS()
Trust region	SNESTR	tr	SNESConverged_TR()
Test Jacobian	SNESTEST	test	



Thank You

For any other info,
Send an email to
m.guarrasi@ Cineca.it